

GROUP 27B

REAR AXLE <4WD>

CONTENTS

GENERAL INFORMATION	27B-2	REAR AXLE HUB ASSEMBLY	27B-8
SERVICE SPECIFICATIONS	27B-3	REMOVAL AND INSTALLATION	27B-8
LUBRICANTS	27B-3	INSPECTION	27B-9
SEALANT AND ADHESIVE	27B-3	DRIVE SHAFT ASSEMBLY	27B-10
SPECIAL TOOLS	27B-4	REMOVAL AND INSTALLATION	27B-10
ON-VEHICLE SERVICE	27B-7	INSPECTION	27B-12
REAR AXLE TOTAL BACKLASH CHECK ..	27B-7	DISASSEMBLY AND REASSEMBLY	27B-13
GEAR OIL LEVEL CHECK	27B-7	DIFFERENTIAL CARRIER	
WHEEL BEARING AXIAL PLAY CHECK ..	27B-7	ASSEMBLY	27B-16
DIFFERENTIAL CARRIER OIL SEAL		REMOVAL AND INSTALLATION	27B-16
REPLACEMENT	27B-8	DIFFERENTIAL SUPPORT MEMBER	
		BUSHING REPLACEMENT	27B-17
		DISASSEMBLY	27B-19
		REASSEMBLY	27B-25

GENERAL INFORMATION

M1271000100359

The rear axle has the following features.

- The wheel bearing is a double-row angular contact ball bearing which incorporates the oil seals and is highly resistant to a thrust load.
- The drive shaft has BJ-TJ constant velocity joints.
- A smaller BJ side boot is used.

- ABS rotor for detecting the wheel speed are press-fitted to the BJ outer wheel.

NOTE:

- TJ: Tripod Joint
- BJ: Birfield Joint

SPECIFICATIONS

Item		Specification	
Wheel bearing	Type	Double-row angular contact ball bearing	
	Bearing (OD x ID) mm		70 x 40
Drive shaft	Type	Outer	BJ
		Inner	TJ
	Length (joint to joint) x outer diameter mm	LH	481 x 22
		RH	571 x 22

CONSTRUCTION DIAGRAM

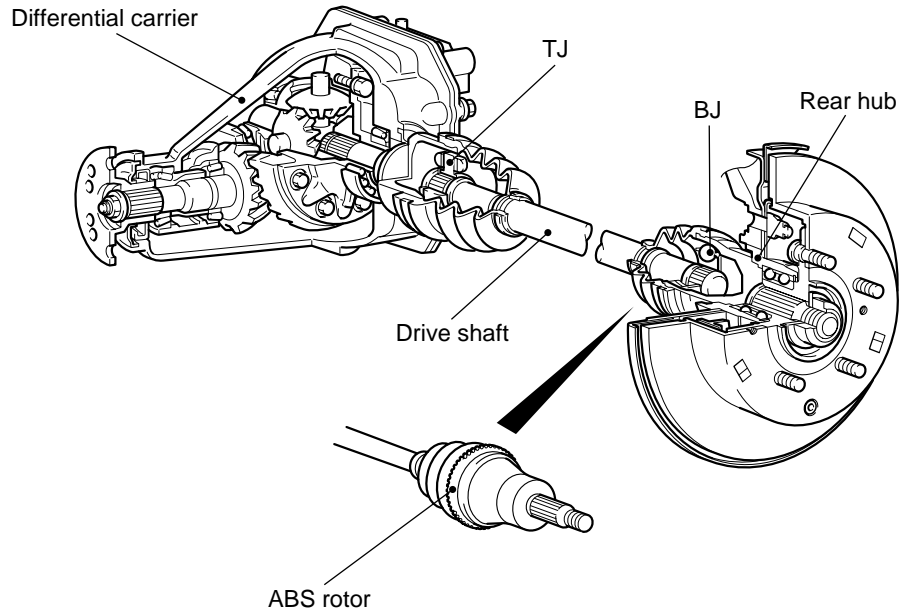

AC300622 AB

SERVICE SPECIFICATIONS

M1271000300535

Item	Standard value		Limit
Rear axle total backlash mm	-		5
Wheel bearing rotation starting torque N·m	-		1.0
Wheel bearing axial play mm	-		0.05
TJ boot assembly dimension mm	80 ± 3		-
Drive gear backlash mm	0.11 – 0.16		-
Drive gear runout mm	-		0.05
Differential gear backlash mm	0 – 0.076		0.2
Drive pinion turning torque N·m	Without oil seal		0.9 – 1.2
	With oil seal	Companion flange (oil seal contacting area) with anti-rust agent	1.0 – 1.3
		Companion flange (oil seal contacting area) with gear oil applied	0.5 – 0.6

LUBRICANTS

M1271000400253

Item	Specified lubricant	Quantity
Rear differential gear oil	Hypoid gear oil API classification GL-5 or higher Above 10°C: SAE 90 Below 10°C: SAE 80W	0.55 L
Drive shaft BJ joint	Repair kit grease	75 ± 10 g
Drive shaft TJ joint	Repair kit grease	110 ± 10 g



SEALANT AND ADHESIVE





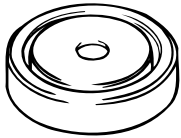
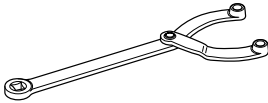
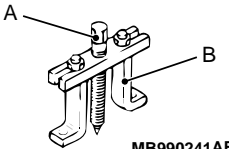

M1271000500227

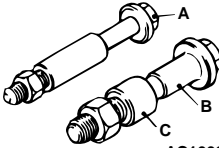
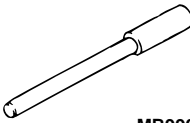
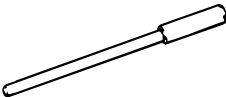
Item	Specified sealant and adhesive	Remark
Differential cover	3M ATD Part No. 8661 or equivalent	Semi-drying sealant
Drive gear and differential case mounting part	3M Stud Locking 4170 or equivalent	Anaerobic sealant

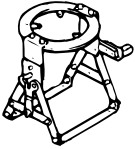
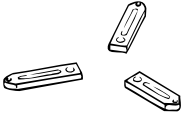
SPECIAL TOOLS

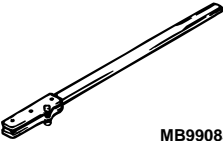
M1271000600440

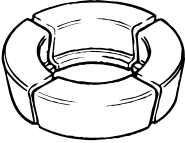
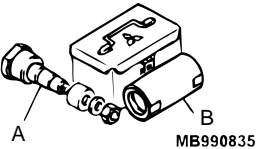
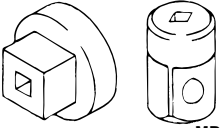
Tool	Number	Name	Use
	MB991115	Oil seal installer	Press-fitting of the differential carrier oil seal (Use together with MB990938)
 B990767	MB990767	End yoke holder	Rear axle hub fixing
 A B MB990241AB	MB990241 A: MB990242 B: MB990244	Axle shaft puller A: Puller shaft B: Puller bar	Removal of the drive shaft
 MB991354	MB991354	Puller body	
 A B C AC100320AB	A: MB991017 B: MB990998 C: MB991000	A, B: Front hub remover and installer C: Spacer	<ul style="list-style-type: none"> • Provisional holding of the wheel bearing • Measurement of wheel bearing rotation starting torque • Measurement of wheel bearing end play <p><i>NOTE: MB991000, which belongs to MB990998, should be used as a spacer.</i></p>
 MB990883	MB990883	Rear suspension bushing arbor	Removal and installation of the differential support member bushing
	MB990884	Mount bushing arbor	

Tool	Number	Name	Use
 <p>MB990909</p>	MB990909	Working base	Supporting of the differential carrier
	MB991116	Working base adapter	
 <p>MB990810</p>	MB990810	Side bearing puller	<ul style="list-style-type: none"> • Removal of the side bearing inner race • Removal of the companion flange
 <p>MB990850</p>	MB990850	End yoke holder	Companion flange fixing
 <p>MB990339</p>	MB990339	Bearing puller	Removal of drive pinion rear bearing inner race
	MB990374	Pinion bearing remover	
 <p>MB990835 A: MB990836 B: MB990392</p>	MB990835 A: MB990836 B: MB990392	Drive pinion setting gauge set A: Drive pinion gauge assembly B: Cylinder gauge	Adjustment of the drive pinion height
 <p>MB990326</p>	MB990326	Preload socket	<ul style="list-style-type: none"> • Measurement of the wheel bearing rotation starting torque • Measurement of the drive pinion turning torque
	MB990685	Torque wrench	

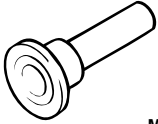
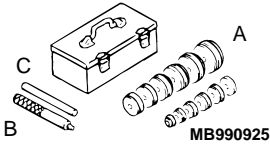
Tool	Number	Name	Use
 <p>MB990728</p>	MB990728	Bearing installer	Press-fitting of the drive pinion rear bearing inner race
 <p>MB990031</p>	MB990031 or MB990699	Oil seal installer	Press-fitting of the drive pinion oil seal
 <p>MB990925</p>	MB990925 A: MB990926 – MB990937 B: MB990938 C: MB990939	Bearing and oil seal installer set A: Installer adapter B: Bar C: Brass bar	<ul style="list-style-type: none"> • Press-fitting of differential carrier oil seal (Use together with MB991115) • Inspection of final drive gear tooth contact • Removal and installation of drive pinion front/rear bearing outer race For details of each installer, refer to GROUP 26 – Special Tools P.26-4.

ON-VEHICLE SERVICE

REAR AXLE TOTAL BACKLASH CHECK

M1271001200218

1. Park the vehicle on a flat, level surface.
2. Move the transmission gearshift lever to the neutral position. Apply the parking brake and jack up the vehicle.

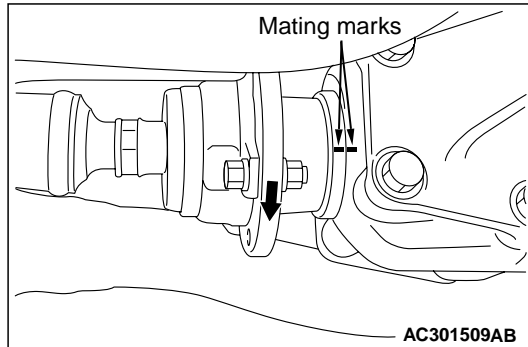

3. Turn the propeller shaft clockwise as far as it will go. Make the mating marks on the companion flange and on the differential carrier.

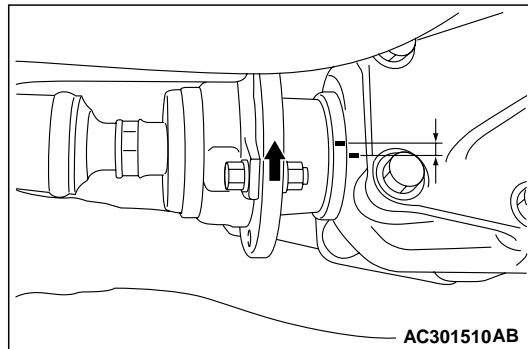

4. Turn the propeller shaft counterclockwise as far as it will go, and measure the amount of distance between the mating marks.

Limit: 5 mm

5. If the backlash exceeds the limit value, remove the differential carrier assembly and check the following.
 - Final drive gear backlash (Refer to [P.27B-19.](#))
 - Differential gear backlash (Refer to [P.27B-19.](#))

GEAR OIL LEVEL CHECK

M1272001200211

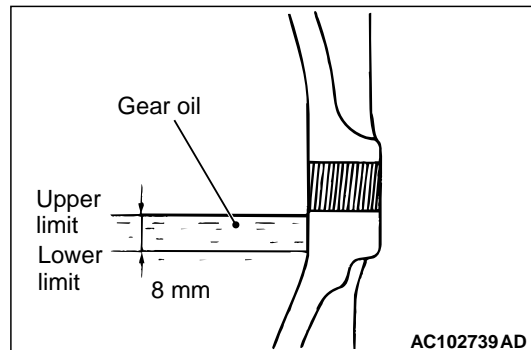

Check that gear oil level is not 8 mm below the bottom of filler plug hole.

Specified gear oil:

Hypoid gear oil API classification GL-5 or higher

Above 10°C: SAE 90

Below 10°C: SAE 80W

WHEEL BEARING AXIAL PLAY CHECK

M1271000900388

1. Remove the caliper assembly, and suspend the caliper assembly with a wire and remove the brake disc.

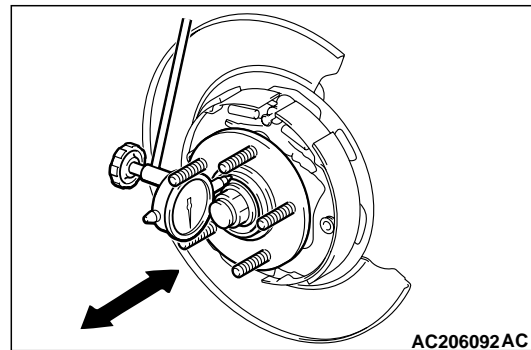

2. Fit the dial gauge as shown in the diagram and move the hub in the axial direction to measure the play.

Limit: 0.05 mm

3. If the play exceeds the limit, the drive shaft nut should be tightened to the specified torque and check the axial play again.

Tightening torque: 245 ± 29 N·m

4. Replace the wheel bearing if adjustment cannot be made to within the limit. (Refer to [GROUP 34-Trailing Arm P.34-13.](#))

DIFFERENTIAL CARRIER OIL SEAL REPLACEMENT

M1272001300111

1. Remove the drive shaft from the differential carrier. (Refer to [P.27B-10](#)).
2. Remove the differential carrier oil seal.

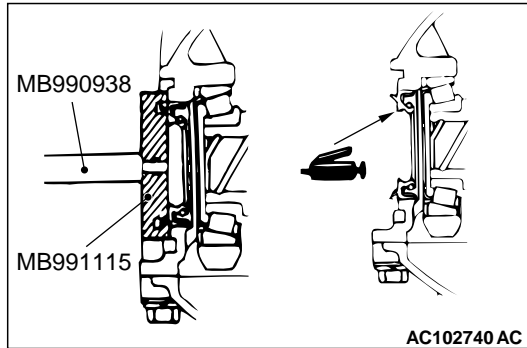

3. Use the following special tools to press-fit a new oil seal.
 - Installer bar (MB990938)
 - Oil seal installer (MB991115)
4. Apply multi-purpose grease to the oil seal lip and drive shaft oil seal seating area.
5. Replace the drive shaft circlip with a new one, and install the drive shaft to the differential carrier. (Refer to [P.27B-10](#)).

REAR AXLE HUB ASSEMBLY

REMOVAL AND INSTALLATION

M1271002000358

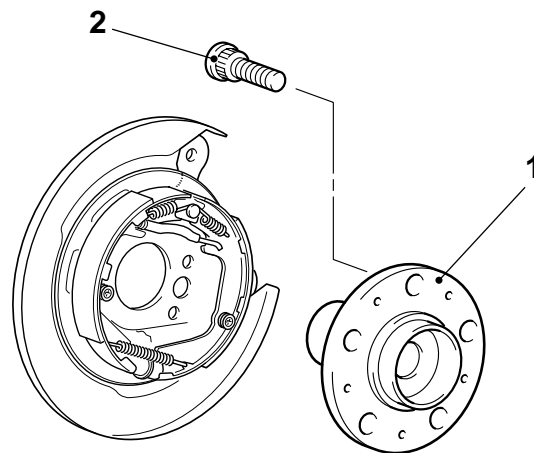

Removal steps

1. Rear hub assembly (Refer to GROUP 34, Trailing arm assembly [P.34-13](#)).
2. Hub bolt

AC301904 AB

INSPECTION

WHEEL BEARING ROTATION STARTING TORQUE AND AXIAL PLAY CHECK

M1271002100236

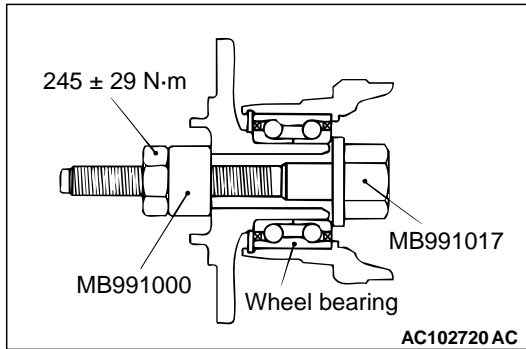

1. Tighten the following special tools to the specified torque.
 - Spacer (MB991000)
 - Front hub remover and installer (MB991017)
2. Rotate the rear hub in order to seat the bearing.

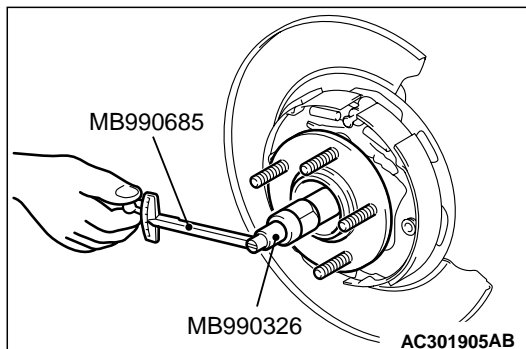

3. Measure the wheel bearing rotation starting torque by using the following special tools.
 - Preload socket (MB990326)
 - Torque wrench (MB990685)

Limit: 1.0 N·m

4. The rotation starting torque must be within the limit and wheel bearing must rotate smoothly.

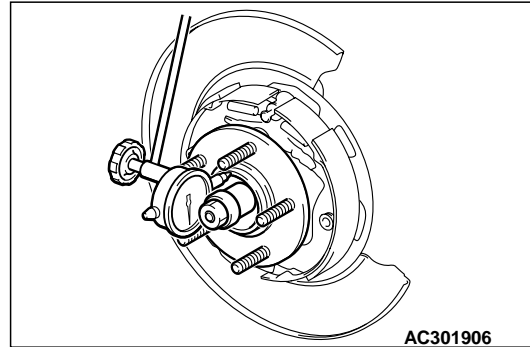

5. Measure to determine whether the wheel bearing axial play is within the specified limit or not.

Limit: 0.05 mm

6. If the play is not within the limit range while the nut is tightened to 245 ± 29 N·m, the bearing, trailing arm and/or rear hub have probably not been installed correctly. Replace the bearing and re-install.

DRIVE SHAFT ASSEMBLY

REMOVAL AND INSTALLATION

M1271003300147

CAUTION

- Do not strike the ABS rotors installed to the BJ outer race of drive shaft against other parts when removing or installing the drive shaft. Otherwise the ABS rotors will be damaged.
- Be careful not to strike the pole piece at the tip of the rear ABS sensor with tools during servicing work.

Pre-installation Operation

- Differential Gear Oil Draining (Refer to [P.27B-7](#)).

Post-installation Operation

- Differential Gear Oil Filling (Refer to [P.27B-7](#)).
- Rear Wheel Alignment Check and Adjustment (Refer to GROUP 34, On-vehicle Service – Rear Wheel Alignment Check and Adjustment [P.34-7](#)).

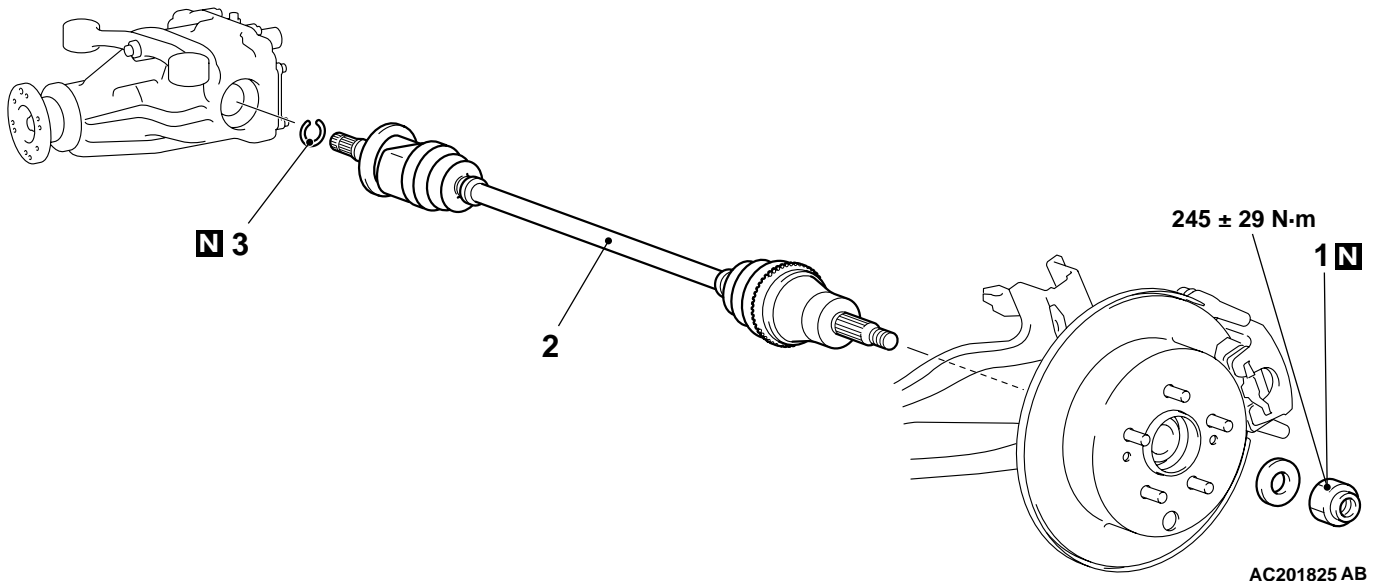

- Removal steps**
- <<A>> >>B<<
1. Drive shaft nut
 - Rear ABS sensor (Refer to GROUP 35B, Wheel Speed Sensor [P.35B-67](#)).
 - Lower arm and trailing arm connection (Refer to Group 34, Trailing arm assembly [P.34-13](#)).

- Removal steps (Continued)**
- <> >>A<<
- Control link and trailing arm connection (Refer to GROUP 34, Trailing arm assembly [P.34-13](#)).
 2. Drive shaft
 3. Circlip

REMOVAL SERVICE POINTS

<<A>> DRIVE SHAFT NUT REMOVAL

⚠ CAUTION

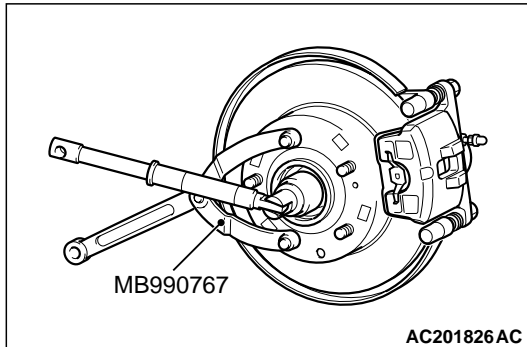

Do not apply pressure to wheel bearing by the vehicle weight to avoid possible damage to wheel bearing before tightening drive shaft nut fully.

Use special tool end yoke holder (MB990767) to fix the hub and remove the drive shaft nut.

<> DRIVE SHAFT REMOVAL

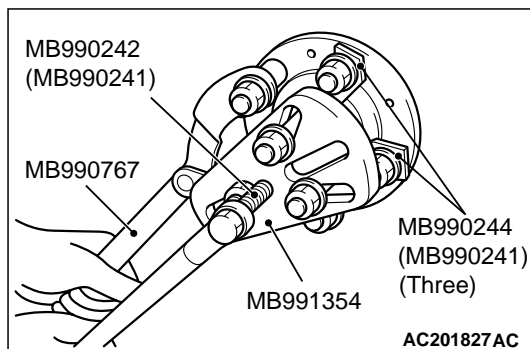

1. Use the following special tools to push out the drive shaft from the hub.

- Puller shaft (MB990242)
- Puller bar (MB990244)
- Puller body (MB991354)
- End yoke holder (MB990767)

⚠ CAUTION

- Do not pull on the drive shaft; doing so will damage the TJ; be sure to use the pry bar.
- When pulling the drive shaft out from the differential carrier, be careful that the spline part of the drive shaft does not damage the oil seal.

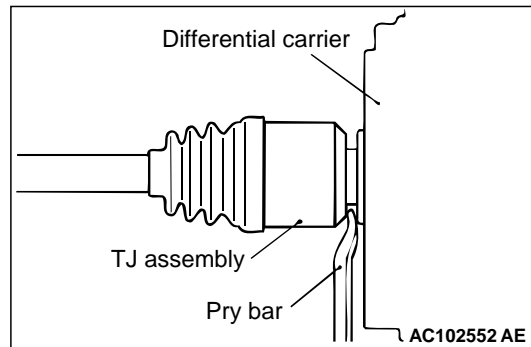

2. Remove the drive shaft from the differential carrier by using a pry bar.

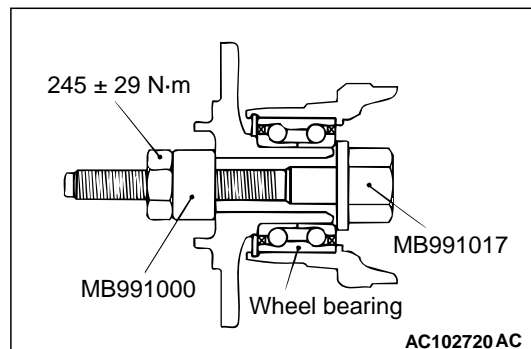

⚠ CAUTION

Do not apply pressure to the wheel bearing by the vehicle weight to avoid possible damage when the drive shaft is removed. If, however, vehicle weight must be applied to the bearing in moving the vehicle, temporarily secure the wheel bearing by using the following special tools.

- Front hub remover and installer (MB991017)
- Spacer (MB991000)

INSTALLATION SERVICE POINTS

>>A<< DRIVE SHAFT INSTALLATION

⚠ CAUTION

When installing the drive shaft, be careful that the spline part of the drive shaft does not damage the oil seal.

>>B<< DRIVE SHAFT NUT INSTALLATION

⚠ CAUTION

Do not apply pressure to wheel bearing by the vehicle weight to avoid possible damage to wheel bearing before tightening drive shaft nut fully.

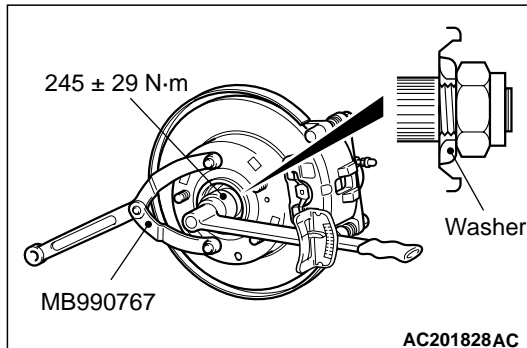

1. Assemble the drive shaft washer in the illustrated direction.
2. Tighten the drive shaft nut to the torque specification with special tool end yoke holder (MB990767).

INSPECTION

M1271003400069

- Check the drive shaft for damage, bending or corrosion.
- Check the drive shaft spline part for wear or damage.
- Check the boots for deterioration, damage or cracking.
- Check the dust cover for damage or deterioration.

DISASSEMBLY AND REASSEMBLY

M1271003500185

CAUTION

- Be careful not to damage the ABS rotor, which is attached to the BJ outer race during disassembly and reassembly.
- Never disassemble the BJ assembly except when replacing the BJ boot.

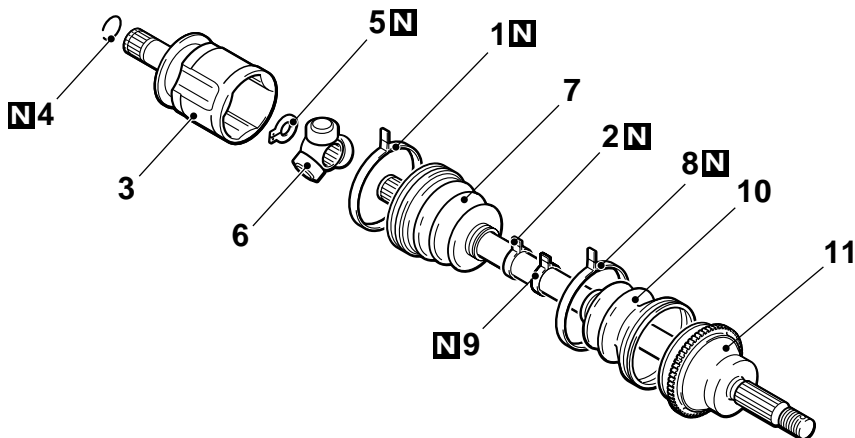

<p>BJ repair kit</p>	<p>TJ repair kit</p>
<p>Grease for TJ Grease for BJ</p>	
<p>BJ boot repair kit</p>	<p>TJ boot repair kit</p>

AC201162AB

- Disassembly steps
- >>C<< 1. TJ boot band (large)
 - >>C<< 2. TJ boot band (small)
 - <<A>> >>B<< 3. TJ case
 - 4. Circlip
 - 5. Snap ring
 - <<A>> >>B<< 6. Spider assembly

- Disassembly steps (Continued)
- <> >>A<< 7. TJ boot
 - 8. BJ boot band (large)
 - 9. BJ boot band (small)
 - <> >>A<< 10. BJ boot
 - 11. BJ assembly

DISASSEMBLY SERVICE POINTS

<<A>> TJ CASE/SPIDER ASSEMBLY REMOVAL

CAUTION

Do not disassemble the spider assembly.

1. Wipe off grease from the TJ case and spider assembly.
2. If there is water or foreign material in the wiped grease, be sure to clean the spider assembly.

<> TJ BOOT/BJ BOOT REMOVAL

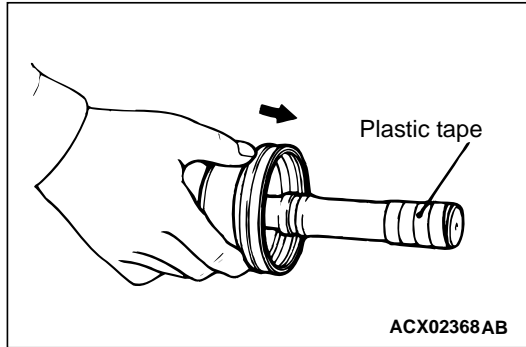

1. Wipe off grease from the shaft spline part.
2. Wrap plastic tape around the spline part on the TJ side of the drive shaft so that TJ and BJ boots are not damaged when they are removed.

REASSEMBLY SERVICE POINTS

>>A<< BJ BOOT/TJ BOOT INSTALLATION

Wrap plastic tape around the spline part on the TJ side of the drive shaft, and then install BJ and TJ boots.

>>B<< SPIDER ASSEMBLY/TJ CASE INSTALLATION

CAUTION

- The drive shaft joint use special grease. Do not mix old and new or different types of grease.
 - If the spider assembly has been cleaned, take special care to apply the specified grease.
1. Apply the specified grease furnished in the repair kit to the spider assembly between the spider axle and the roller.

Specified grease: Repair kit grease

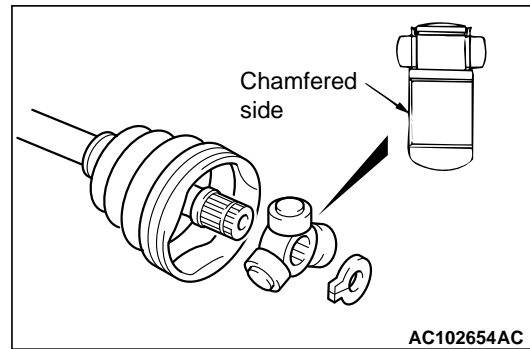

2. Install the spider assembly to the shaft from the direction of the spline chamfered side.

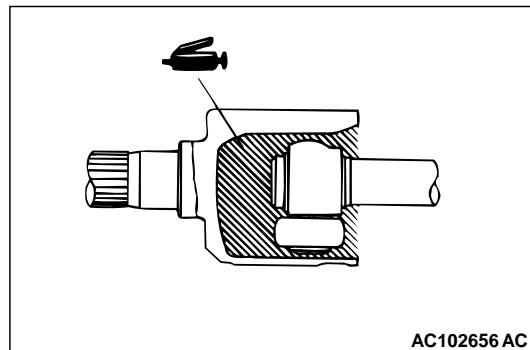

3. After applying the specified grease to the TJ case, insert the driveshaft and apply grease one more time.

Specified grease: Repair kit grease

Used amount: 110 ± 10 g

NOTE: The grease in the repair kit should be divided in half for use, respectively, at the joint and inside the boot.

>>C<< TJ BOOT BAND (SMALL)/TJ BOOT BAND (LARGE) INSTALLATION

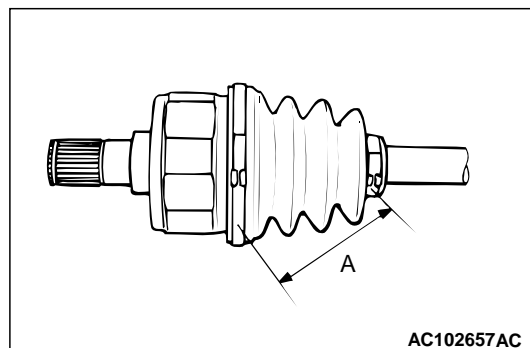

Set the TJ boot bands at the specified distance in order to adjust the amount of air inside the TJ boot, and then tighten the TJ boot band (large) and TJ boot band (small) securely.

Standard value (A): 80 ± 3 mm

DIFFERENTIAL CARRIER ASSEMBLY

REMOVAL AND INSTALLATION

M1272002000254

Pre-removal Operation

- Main Muffler and Centre Exhaust Pipe Removal (Refer to GROUP 15, Exhaust Pipe and Muffler P.15-13).
- Differential Gear Oil Draining
- Drive Shaft Removal (Refer to P.27B-10).

Post-installation Operation

- Drive Shaft Installation (Refer to P.27B-10).
- Differential Gear Oil Filling (Refer to P.27B-7).
- Main Muffler and Centre Exhaust Pipe Installation (Refer to GROUP 15, Exhaust Pipe and Muffler P.15-13).
- Rear Wheel Alignment Check and Adjustment (Refer to GROUP 34, On-vehicle Service-Rear Wheel Alignment Check and Adjustment P.34-7).

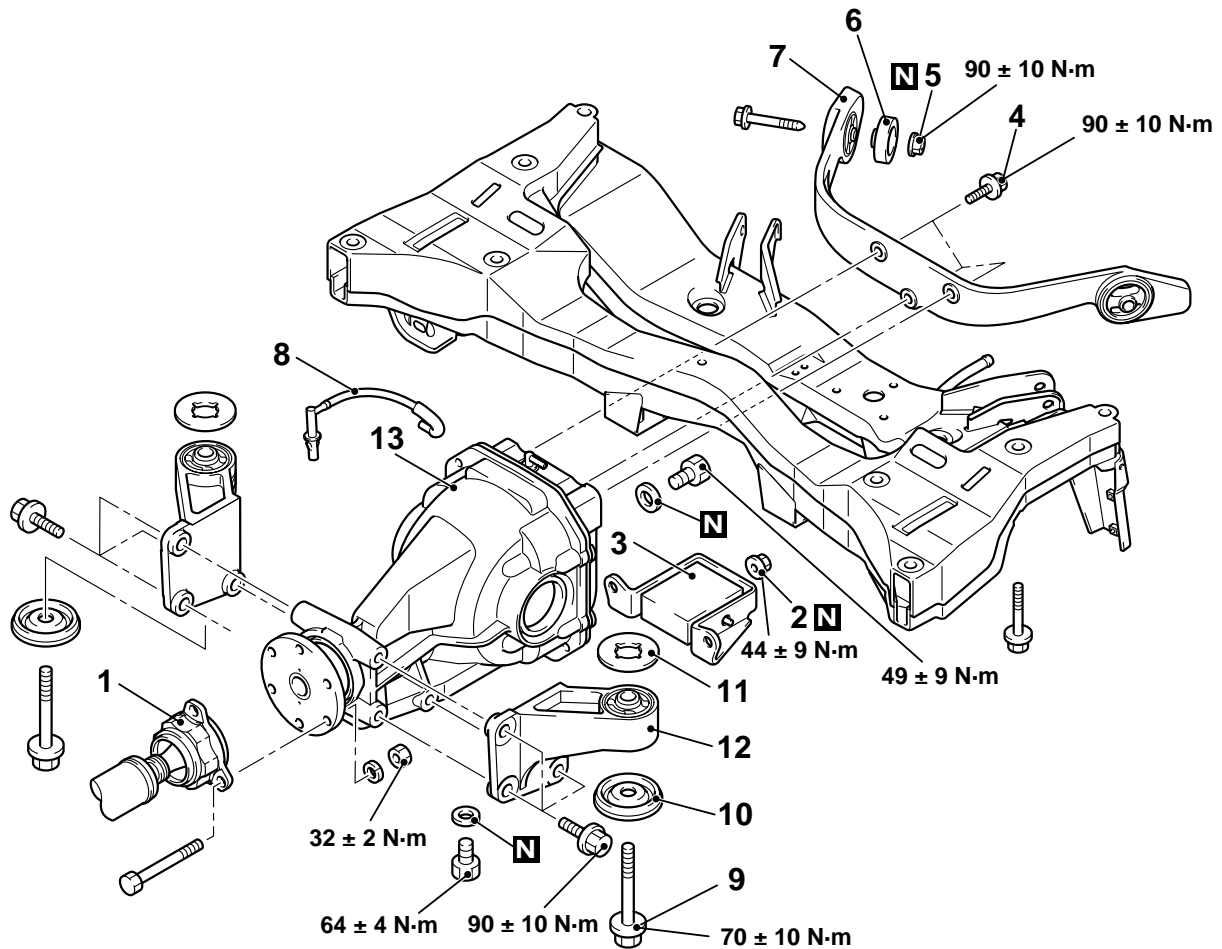

AC304071AC

- Removal steps**
- <<A>> >>B<<
1. Propeller shaft connection
 2. Self-locking nut
 3. Dynamic damper
 4. Differential support arm connecting bolt
 5. Self-locking nut
 6. Rear differential support weight

- Removal steps (Continued)**
- >>A<<
7. Differential support arm
 8. Breather hose assembly
 9. Differential mount bracket bolt
 10. Lower stopper
 11. Upper stopper
 12. Differential mount bracket
 13. Differential carrier assembly

REMOVAL SERVICE POINTS

<<A>> PROPELLER SHAFT DISCONNECTION

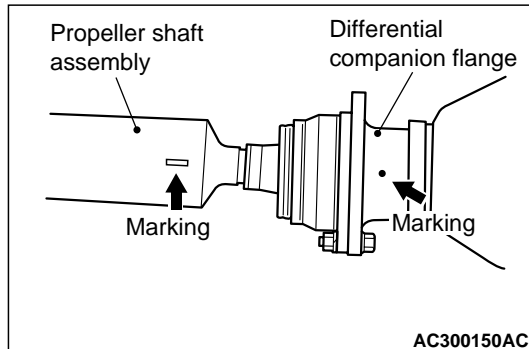

1. Make mating marks on the differential companion flange and the propeller shaft assembly.
2. Suspend the removed propeller shaft from the body with a wire to prevent bending.

INSTALLATION SERVICE POINTS

>>A<< BREATHER HOSE ASSEMBLY INSTALLATION

CAUTION

Be careful not to apply grease, water or soapy water to the hose inlet.

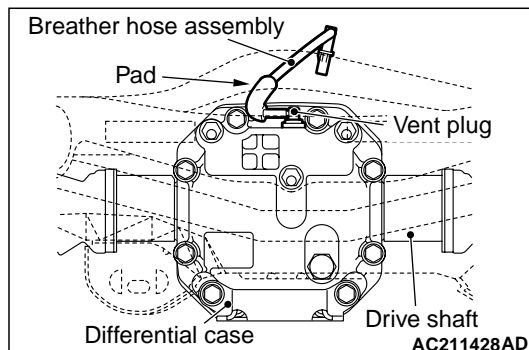

Fully insert the breather hose into the vent plug. Install the breather hose pad as shown in the illustration.

>>B<< PROPELLER SHAFT INSTALLATION

Align the mating marks of differential companion flange and propeller shaft assembly.

DIFFERENTIAL SUPPORT MEMBER BUSHING REPLACEMENT

M1272001400077

<DIFFERENTIAL MOUNT BRACKET>

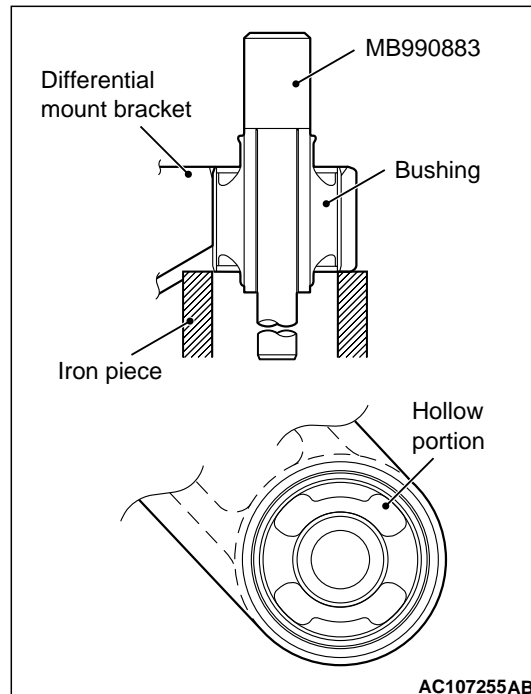

1. Use special tool rear suspension bushing arbor (MB990883) to remove or install the bushing.
2. Press-fit the bushing with its hollow portion facing in the direction shown.
3. Press-fit the bushing until the bushing outer case end face is flush with the differential mount bracket.

<DIFFERENTIAL SUPPORT ARM>

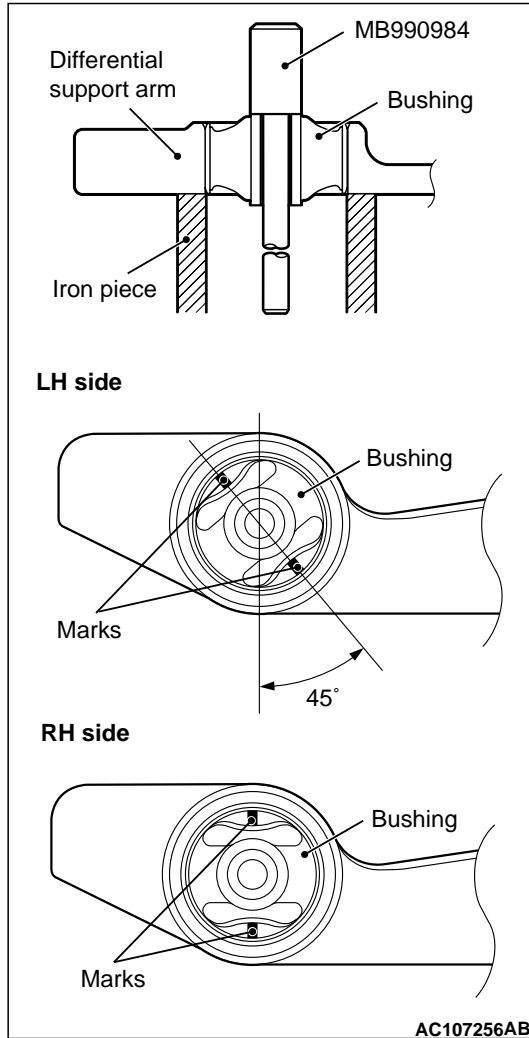

1. Use special tool mont bushing arbor (MB990984) to remove or install the bushing.
2. Press-fit the bushing with its marks facing in the direction shown.
3. Press-fit the bushing until the bushing outer case end face is flush with the differential support arm.

DISASSEMBLY

M1272002200203

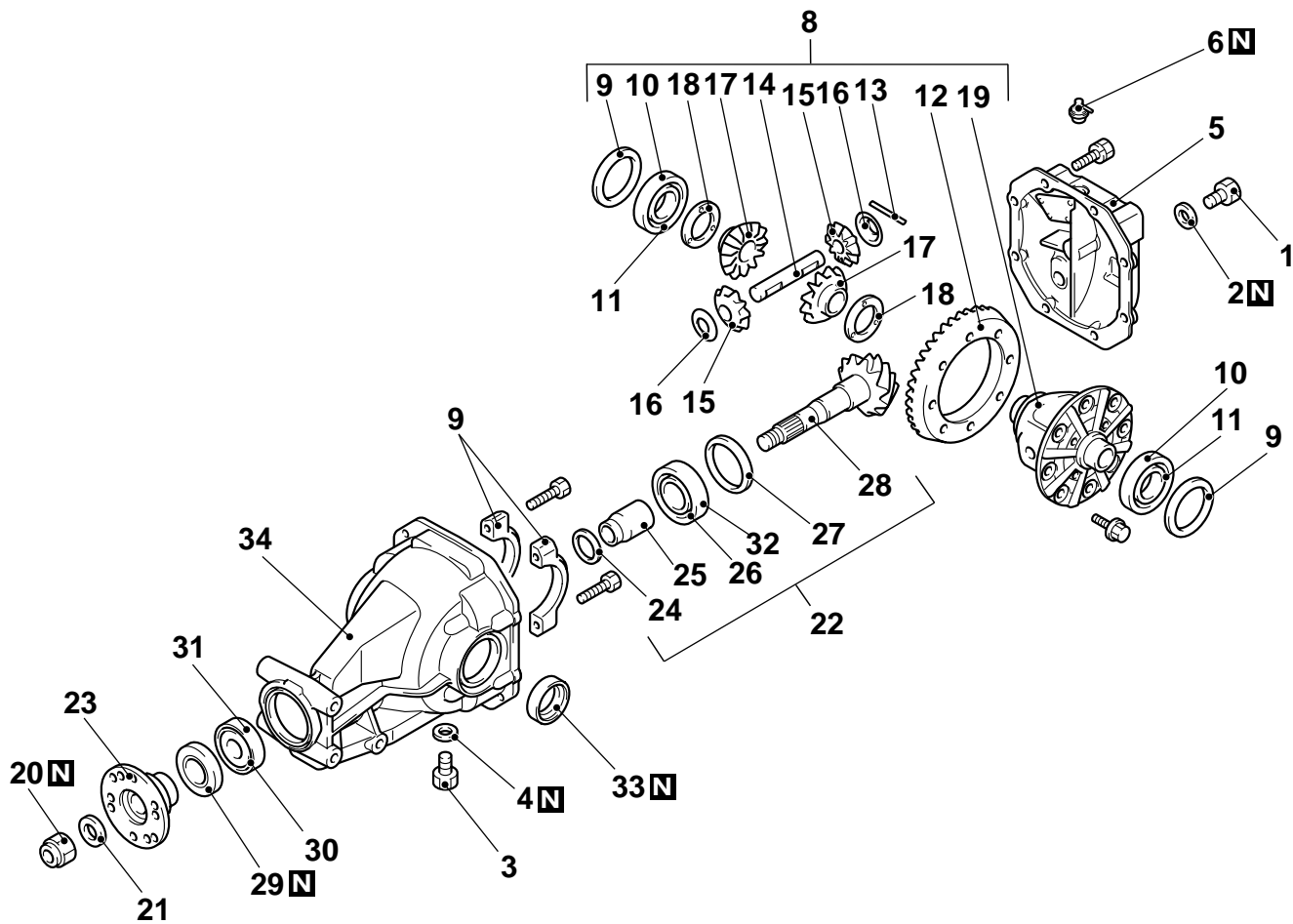

AC301212AB

Disassembly steps

- Inspection before disassembly (Refer to P.27B-20).
- 1. Filler plug <<E>>
- 2. Gasket
- 3. Drain plug <<F>>
- 4. Packing <<F>>
- 5. Differential cover
- 6. Vent plug
- 7. Bearing pin
- 8. Differential case assembly <<G>>
- 9. Differential side bearing spacer
- 10. Differential side bearing outer race
- 11. Differential side bearing inner race
- 12. Drive gear <<H>>
- 13. Lock pin <<H>>
- 14. Pinion shaft <<H>>
- 15. Pinion gear <<I>>
- 16. Pinion washer
- 17. Side gear

<<A>>
<<A>>
<<A>>
<>
<<C>>
<<D>>

Disassembly steps (Continued)

- 18. Side gear spacer
- 19. Differential case
- 20. Self-locking nut
- 21. Washer
- 22. Drive pinion assembly
- 23. Companion flange
- 24. Drive pinion front shim (For adjusting preload of drive pinion)
- 25. Drive pinion spacer
- 26. Drive pinion rear bearing inner race
- 27. Drive pinion rear shim (for adjusting drive pinion height)
- 28. Drive pinion
- 29. Oil seal
- 30. Drive pinion front bearing inner race
- 31. Drive pinion front bearing outer race
- 32. Drive pinion rear bearing outer race
- 33. Oil seal
- 34. Differential carrier

INSPECTION BEFORE DISASSEMBLY

1. Remove the cover.

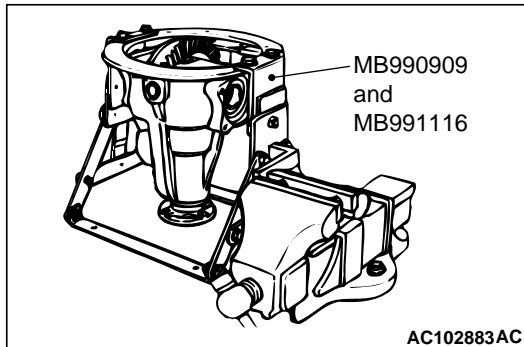

2. Hold the following special tools in a vise, and install the differential carrier assembly to the special tool.

- Working base (MB990909)
- Working base adapter (MB991116)

FINAL DRIVE GEAR BACKLASH

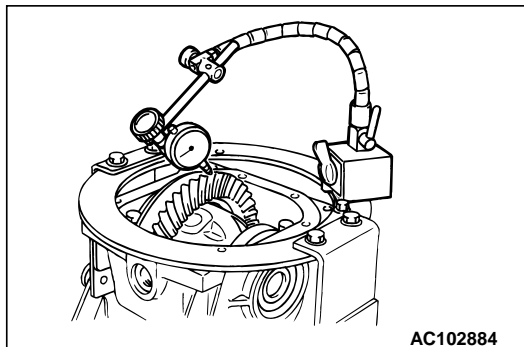

1. With the drive pinion locked in place, use a dial gauge to measure the drive gear backlash in four or more places on the drive gear.

Standard value: 0.11 – 0.16 mm

2. If the backlash is not within the standard value, adjust the final drive gear backlash (Refer to [P.27B-25](#)).
3. After the adjustment, inspect the final drive gear tooth contact.

DRIVE GEAR RUNOUT

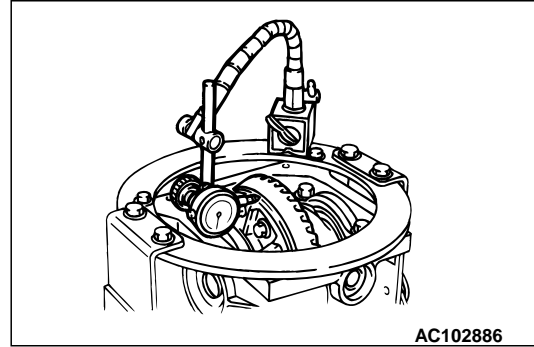

1. Measure the drive gear runout at the shoulder on the reverse side of the drive gear.

Limit: 0.05 mm

2. When runout exceeds the limit value, check for foreign material between drive gear rear side and differential case, or for loose drive gear installation bolts.
3. When step (2) gives normal results, reposition the drive gear and differential case and remeasure.
4. If adjustment is impossible, replace the differential case, or replace the drive gear and pinion as a set.

DIFFERENTIAL GEAR BACKLASH

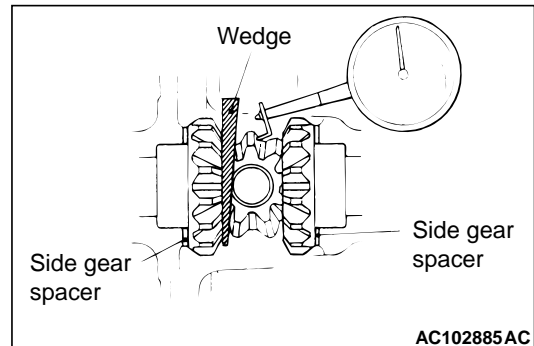

1. Insert a wedge between the side gear and the pinion shaft to lock the side gear.
2. While locking the side gear with the wedge, measure the differential gear backlash with a dial indicator on the pinion gear.

Use the measurement procedure for the other pinion gear.

Standard value: 0 – 0.076 mm

Limit: 0.2 mm

3. If the backlash exceeds the limit value, adjust it by replacing the side gear spacers.
4. If adjustment is not possible, replace the side gears and pinion gears as a set.

FINAL DRIVE GEAR TOOTH CONTACT

Check the tooth contact of drive gear by following the steps below.

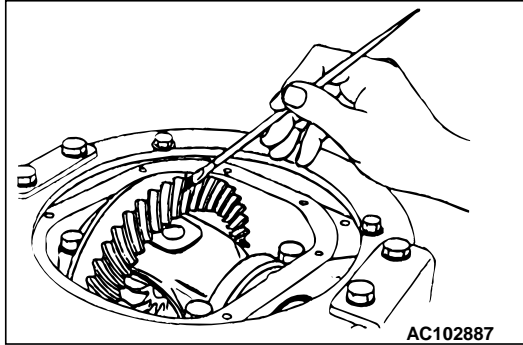

1. Apply a thin, uniform coat of machine blue to both surfaces of the drive gear teeth.

⚠ CAUTION

If the drive gear is rotated too much, the tooth contact pattern will become unclear and difficult to check.

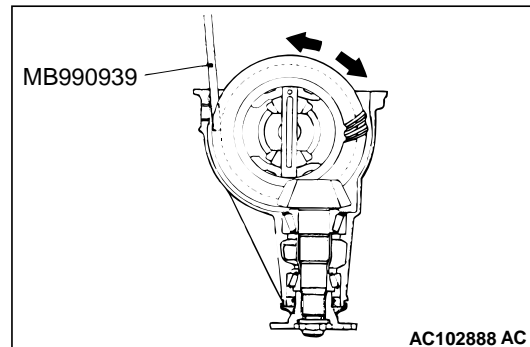

2. Insert special tool brass bar (MB990939) between the differential carrier and the differential case, and then rotate the companion flange by hand (once in the normal direction, and then once in the reverse direction) while applying a load to the drive gear so that the revolution torque (approximately 2.5 – 3.0 N·m) is applied to the drive pinion.
3. Check the tooth contact condition of the drive gear and drive pinion.

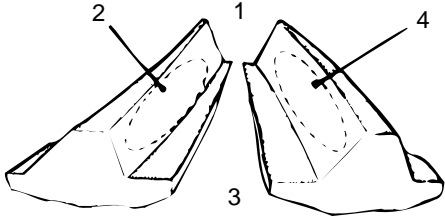
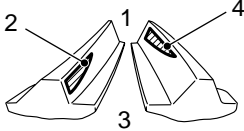
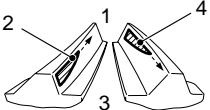
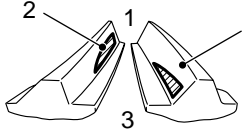
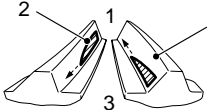
Standard tooth contact pattern	Problem	Solution
<p>1. Narrow tooth side 2. Drive-side tooth surface (the side applying power during forward movement) 3. Wide tooth side 4. Coast-side tooth surface (the side applying power during reverse movement)</p>  <p style="text-align: right;">ACX01039 AF</p>	<p>Tooth contact pattern resulting from excessive pinion height</p>  <p style="text-align: right;">AC107260 AB</p> <p>The drive pinion is positioned too far from the centre of the drive gear.</p>	 <p style="text-align: right;">AC107261 AB</p> <p>Increase the thickness of the drive pinion rear shim, and position the drive pinion closer to the centre of the drive gear. Also, for backlash adjustment, position the drive gear farther from the drive pinion.</p>
This cell is shared with the standard pattern diagram above	<p>Tooth contact pattern resulting from insufficient pinion height</p>  <p style="text-align: right;">AC107262 AB</p> <p>The drive pinion is positioned too close to the centre of the drive gear.</p>	 <p style="text-align: right;">AC107263 AB</p> <p>Decrease the thickness of the drive pinion rear shim, and position the drive pinion farther from the centre of the drive gear. Also, for backlash adjustment, position the drive gear closer to the drive pinion.</p>

NOTE: Check the tooth contact pattern to confirm that the adjustments of the pinion height and backlash have been done properly. Continue to adjust the pinion height and backlash until the tooth contact pattern resembles the standard

pattern. If, even after adjustments have been made, the correct tooth contact pattern cannot be obtained, it means that the drive gear and the drive pinion have become worn beyond the allowable limit. Replace the gear set.

DISASSEMBLY SERVICE POINTS

<<A>> DIFFERENTIAL CASE ASSEMBLY/DIFFERENTIAL SIDE BEARING SPACER/DIFFERENTIAL SIDE BEARING OUTER RACE REMOVAL

CAUTION

When taking out the differential case assembly, be careful not to drop and damage the differential side bearing spacers and differential side bearing outer races.

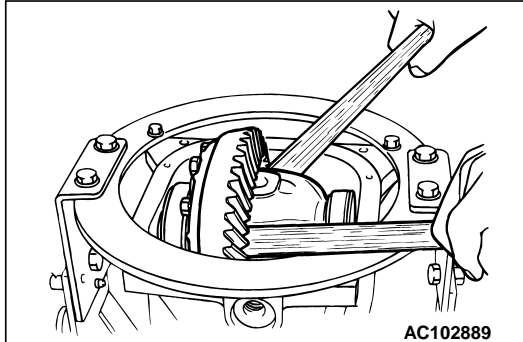

Use the wooden handle of a hammer to remove the differential case assembly, differential side bearing spacers and differential side bearing outer races.

NOTE: Keep the right and left side bearings and side bearing spacers separate, so that they do not become mixed during reassembly.

<> DIFFERENTIAL SIDE BEARING INNER RACE REMOVAL

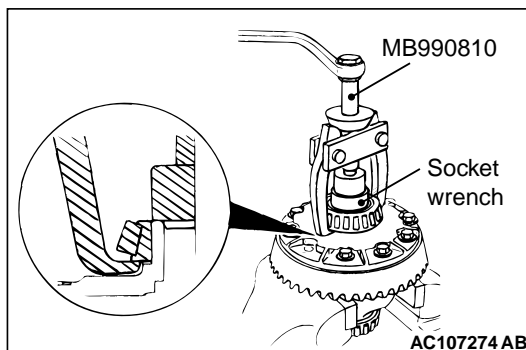

Use special tool side bearing puller (MB990810) to pull out the side bearing inner races.

NOTE: There are two notches provided (at the differential case side) for the claw part of the special tools; use special tool at that position.

<<C>> DRIVE GEAR REMOVAL

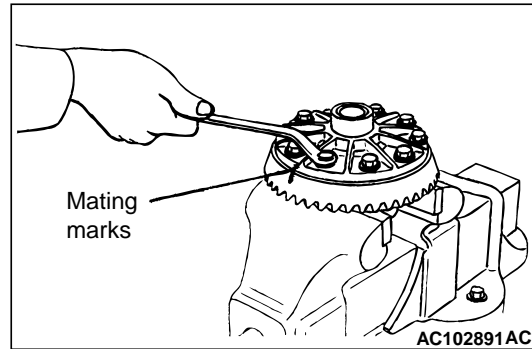

1. Make the mating marks to the differential case and the drive gear.
2. Loosen the drive gear attaching bolts in a diagonal sequence to remove the drive gear.

<<D>> LOCK PIN REMOVAL

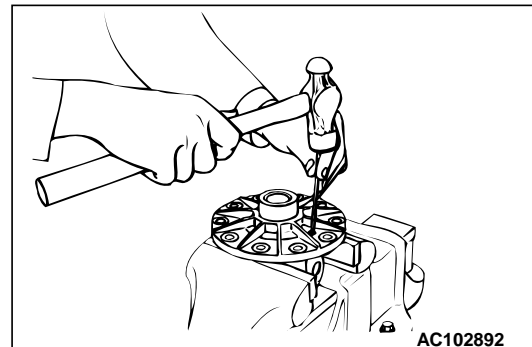

Drive out the lock pin with a punch.

<<E>> SELF-LOCKING NUT REMOVAL

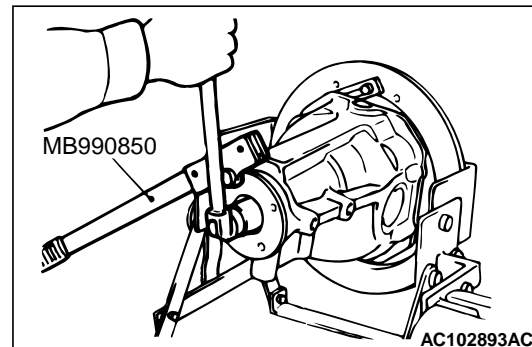

Use special tool end yoke holder (MB990850) to hold the companion flange, and then remove the companion flange self-locking nut.

<<F>> DRIVE PINION ASSEMBLY/COMPANION FLANGE REMOVAL

CAUTION

The mating mark made on the companion flange must not be on the coupling surface of the companion flange and the front propeller shaft.

1. Make mating marks on the drive pinion and companion flange.

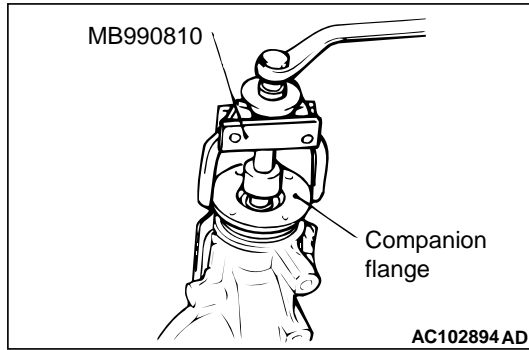

2. Use special tool side bearing puller (MB990810) to pull out the companion flange.

<<G>> DRIVE PINION REAR BEARING INNER RACE REMOVAL

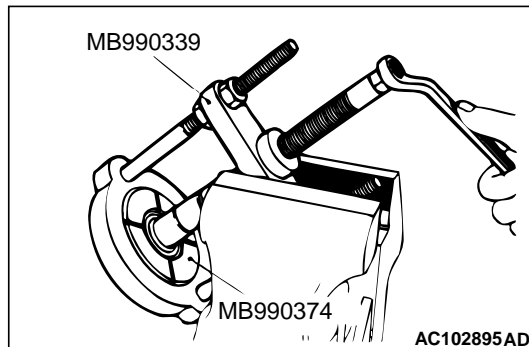

Use the following special tools to pull out the drive pinion rear bearing inner race.

- Bearing puller (MB990339)
- Pinion bearing remover (MB990374)

<<H>> OIL SEAL/DRIVE PINION FRONT BEARING INNER RACE/DRIVE PINION FRONT BEARING OUTER RACE REMOVAL

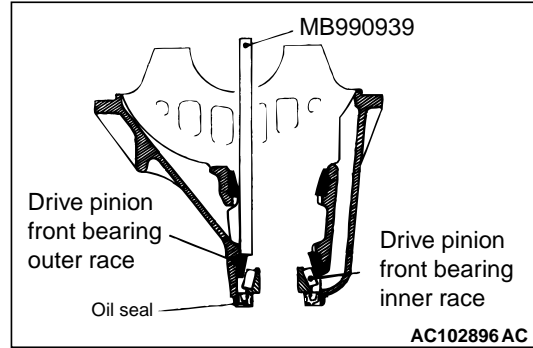

Use special tool bras bar (MB990939) to remove the oil seal, drive pinion front bearing inner race, and drive pinion front bearing outer race.

<<I>> DRIVE PINION REAR BEARING OUTER RACE REMOVAL

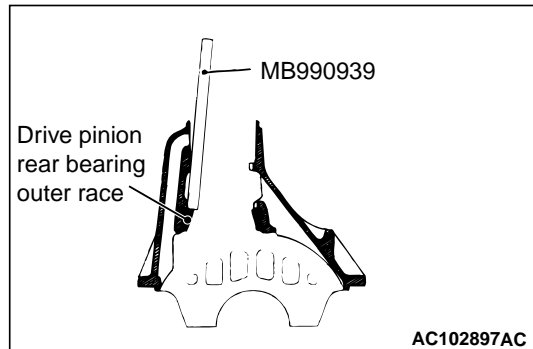

Use special tool bras bar (MB990939) to remove the drive pinion rear bearing outer race.

REASSEMBLY

M1272002300288

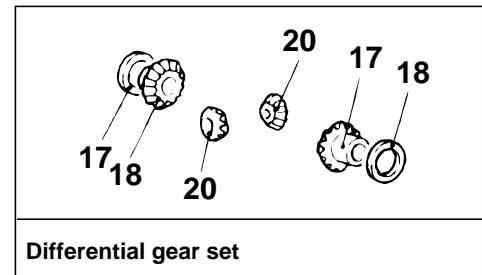
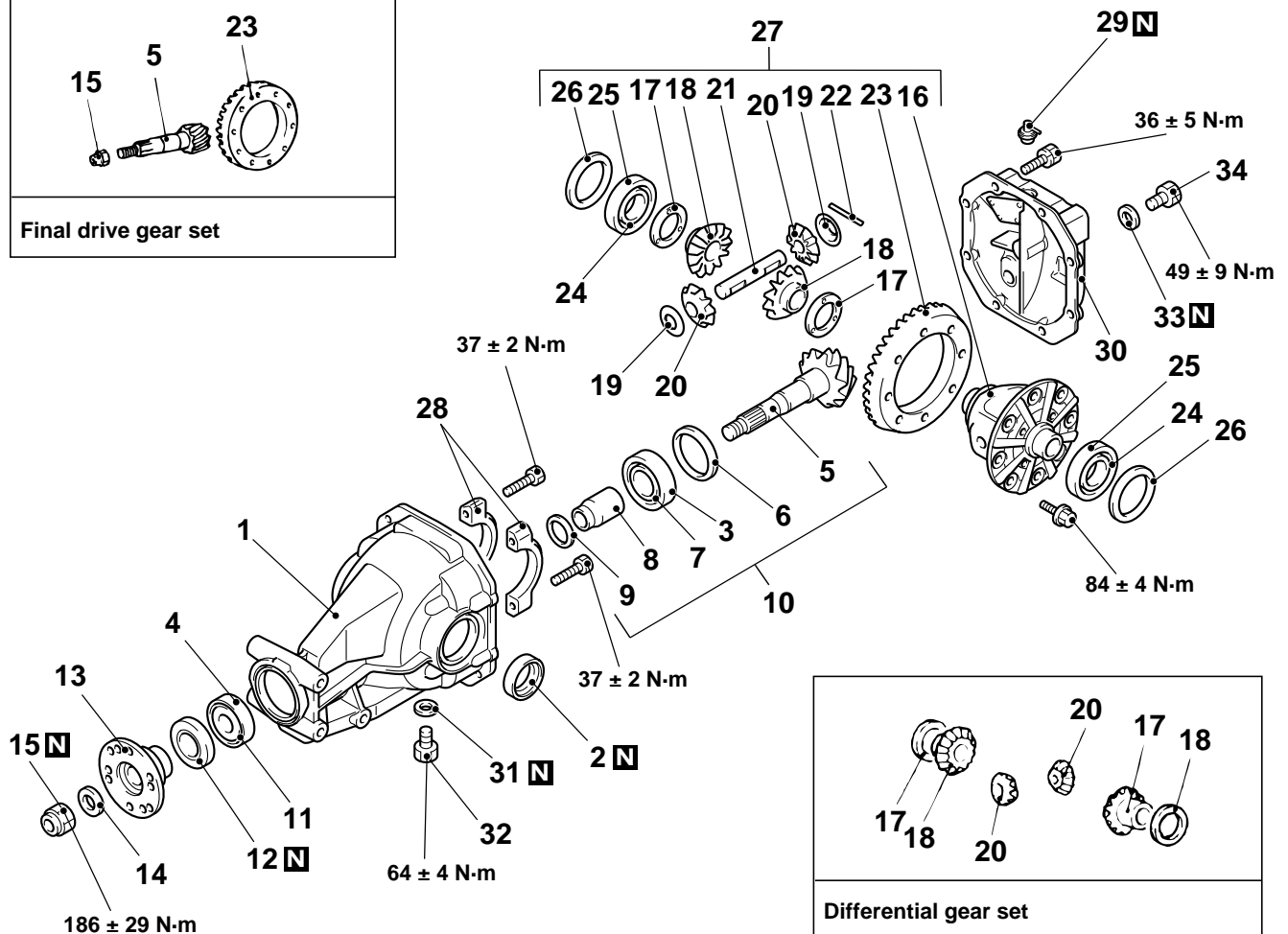
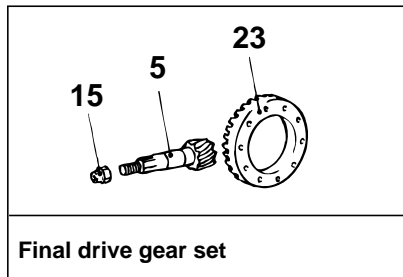

AC301213AB

Reassembly steps

- 1. Differential carrier
- >>A<< 2. Oil seal
- >>B<< 3. Drive pinion rear bearing outer race
- >>C<< 4. Drive pinion front bearing outer race
- >>D<< • Drive pinion height adjustment
- 5. Drive pinion
- 6. Drive pinion rear shim (for adjusting drive pinion height)
- 7. Drive pinion rear bearing inner race
- 8. Drive pinion spacer
- >>E<< • Drive pinion turning torque adjustment
- 9. Drive pinion front shim (for adjusting drive pinion turning torque)
- 10. Drive pinion assembly
- 11. Drive pinion front bearing inner race
- >>E<< 12. Oil seal
- 13. Companion flange
- 14. Washer
- 15. Self-locking nut
- 16. Differential case

Reassembly steps (Continued)

- >>F<< • Differential gear backlash adjustment
- 17. Side gear spacer
- 18. Side gear
- 19. Pinion washer
- 20. Pinion gear
- 21. Pinion shaft
- >>G<< 22. Lock pin
- >>H<< 23. Drive gear
- >>I<< 24. Differential side bearing inner race
- 25. Differential side bearing outer race
- 26. Differential side bearing spacer
- 27. Differential case assembly
- >>J<< 28. Bearing cap
- 29. Vent plug
- 30. Differential cover
- 31. Packing
- 32. Drain plug
- 33. Gasket
- 34. Filler plug
- >>J<< • Final drive gear backlash adjustment

Lubrication and Adhesive Points

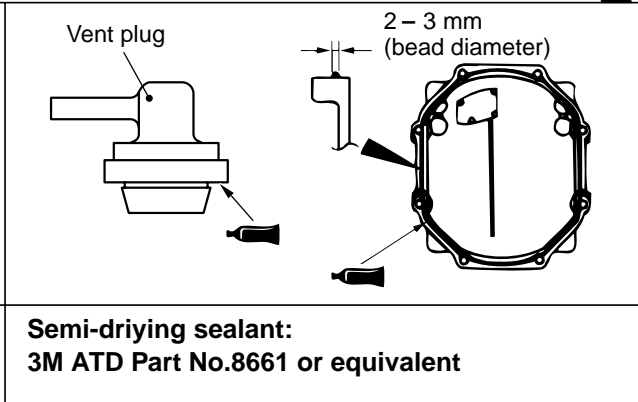
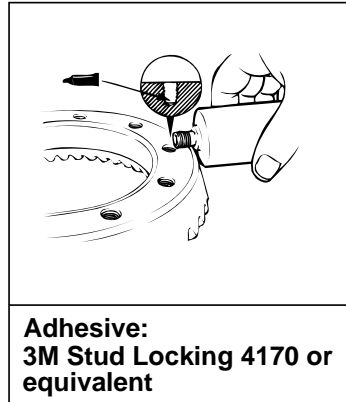
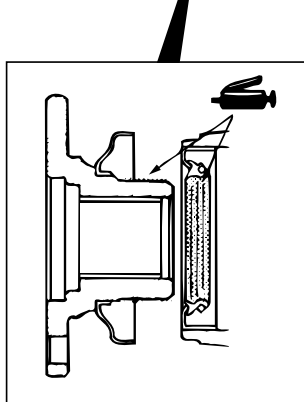
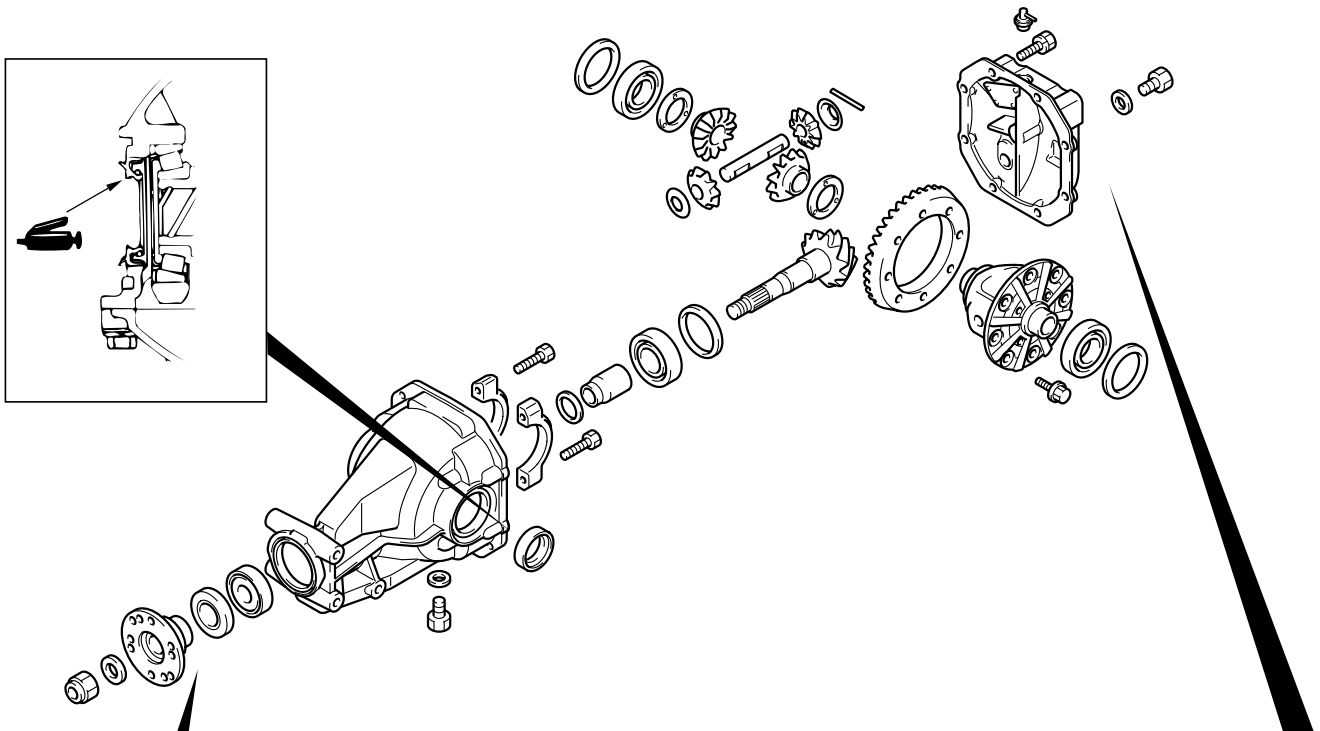

AC301214 AB

REASSEMBLY SERVICE POINTS

>>A<< OIL SEAL PRESS-FITTING

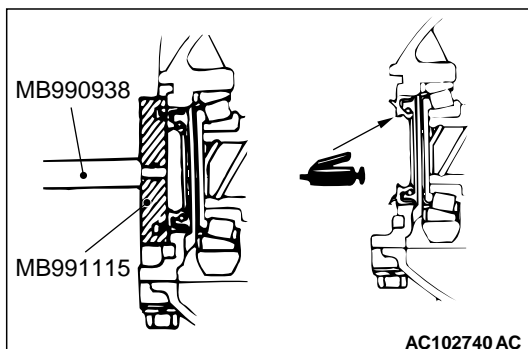

Use the following special tools to press-fit a new oil seal.

- Installer bar (MB990938)

>>B<< DRIVE PINION REAR BEARING OUTER RACE PRESS-FITTING

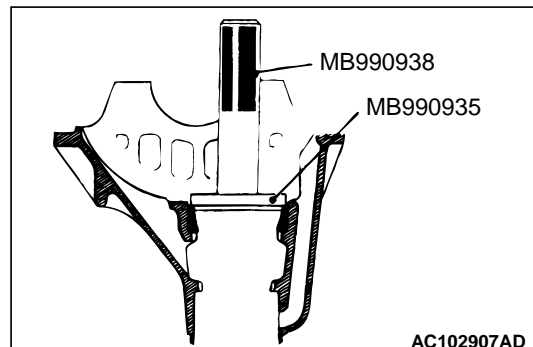

Use the following special tools to press-fit the drive pinion rear bearing outer race.

- Installer bar (MB990938)
- Installer adapter (MB990935)

>>C<< DRIVE PINION FRONT BEARING OUTER RACE PRESS-FITTING

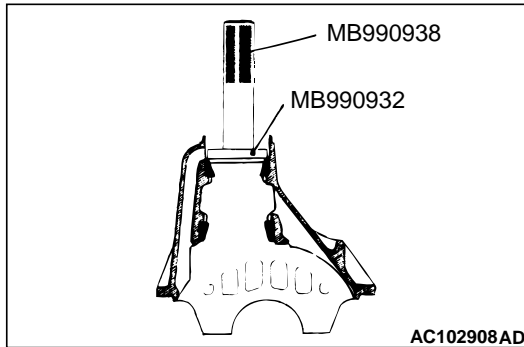

Use the following special tools to press-fit the drive pinion front bearing outer race.

- Installer bar (MB990938)
- Installer adapter (MB990932)

>>D<< DRIVE PINION HEIGHT ADJUSTMENT

Adjust the drive pinion height by the following procedures:

1. Apply multipurpose grease to the washer of special tool drive pinion gauge assembly (MB990836).

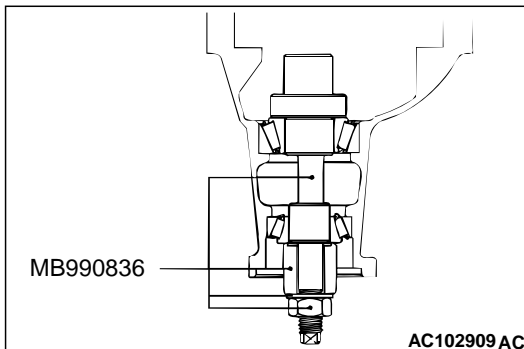

2. Install special tool, drive pinion front and rear bearing inner races to the differential carrier as shown in the illustration.

CAUTION

There should be no gear oil adhered to the bearing.

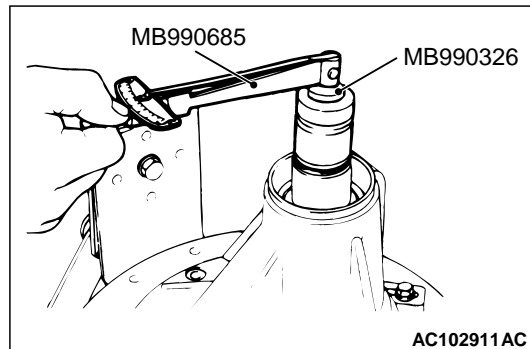
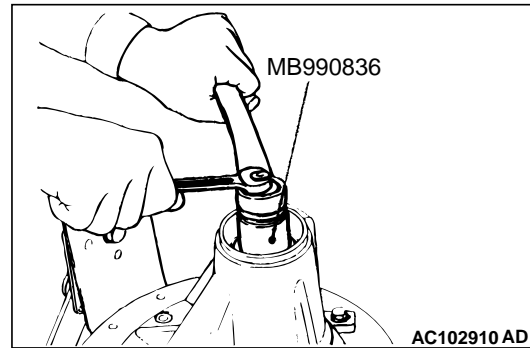

3. Tighten the nut of special tool a little at a time, while measuring the turning torque of the drive pinion by using the following special tools. Then confirm that the turning torque (without the drive pinion oil seal) is at the standard value.

- Preload socket (MB990326)
- Torque wrench (MB990685)

Standard value:

Bearing division	Turning torque
New	0.9 – 1.2 N·m

NOTE: Because the special tool preload socket (MB990326) cannot be turned one turn, turn it several times within the range that it can be turned; then, after fitting to the bearing, measure the turning torque.

4. Clean the side bearing seat of the differential carrier and bearing caps.

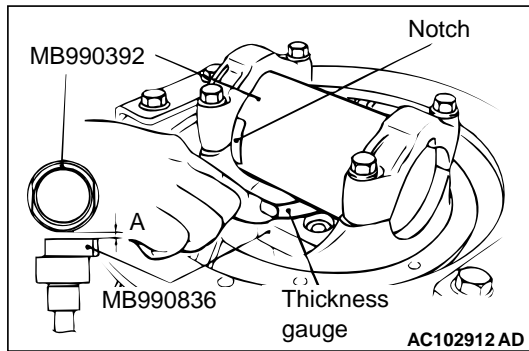

5. Place the following special tools in the side bearing seat of the differential carrier, and position the notch as shown in the illustration. Then install the bearing caps.
 - Cylinder gauge (MB990392)
 - Drive pinion gauge assembly (MB990836)
6. Use a thickness gauge to measure the clearance (A) between special tools.
7. Remove the bearing caps and special tools.

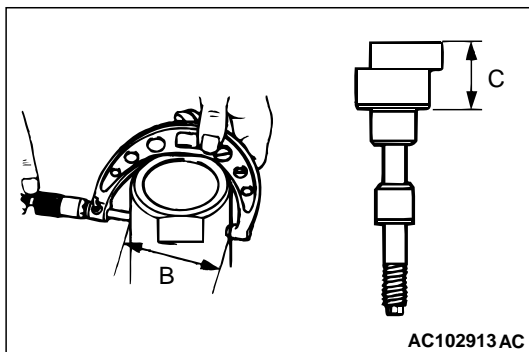

8. Use a micrometer to measure the shown dimensions (B, C) of special tools.

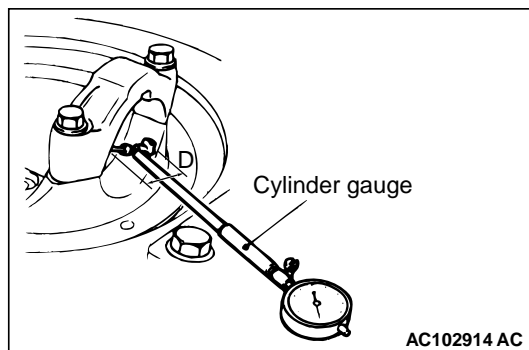

9. Install the bearing cap, and then use a cylinder gauge to measure the inside diameter (D) of the bearing cap.

10. Calculate thickness (F) of the required drive pinion rear shim by the following formula. Select a shim which most closely matches this thickness.

$$F = A + B + C - 1/2D - 86.00 \text{ mm}$$

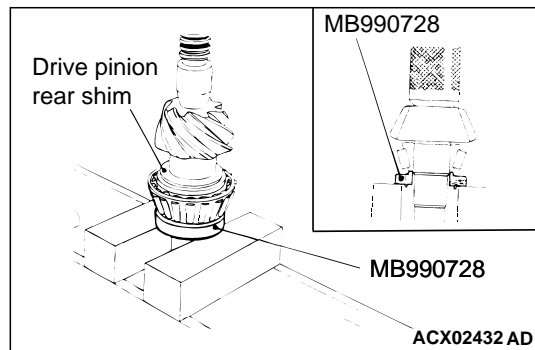

11. Fit the selected drive pinion rear shim(s) to the drive pinion, and press-fit the drive pinion rear bearing inner race by using special tool bearing installer (MB990728).

>>E<< DRIVE PINION TURNING TORQUE ADJUSTMENT/OIL SEAL INSTALLATION

Adjust the drive pinion turning torque by the following procedures:

1. Insert the drive pinion into the differential carrier, and then install the following parts in sequence from the carrier rear side: drive pinion spacer, drive pinion front shim, drive pinion front bearing inner race and companion flange.

NOTE: Do not install the oil seal.

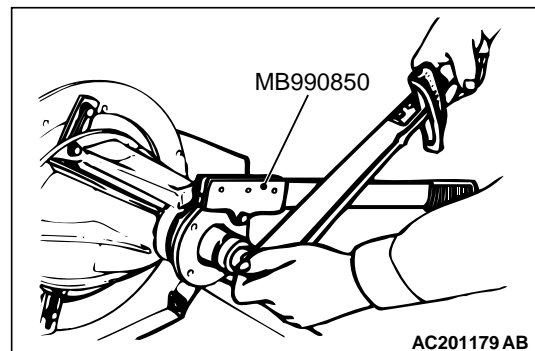

2. Tighten the companion flange self-locking nut to the specified torque while holding the companion flange with special tool end yoke holder (MB990850).

Tightening torque: 186 ± 29 N·m

CAUTION

There should be no gear oil adhered to the bearing.

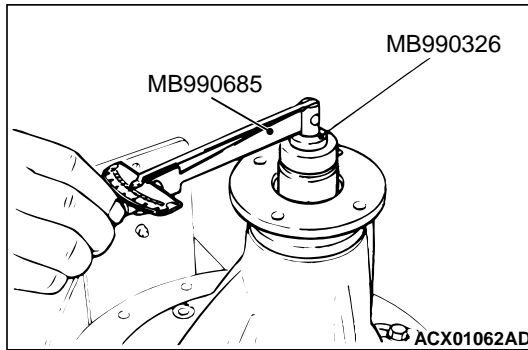

- Use the following special tools MB990685 and MB990326 to measure the drive pinion turning torque (without the drive pinion oil seal).
 - Preload socket (MB990326)
 - Torque wrench (MB990685)

Standard value:

Bearing division	Turning torque
New	0.9 – 1.2 N·m

- If the drive pinion turning torque is not within the standard value, adjust the turning torque by replacing the drive pinion front shim(s) or the drive pinion spacer.

NOTE:

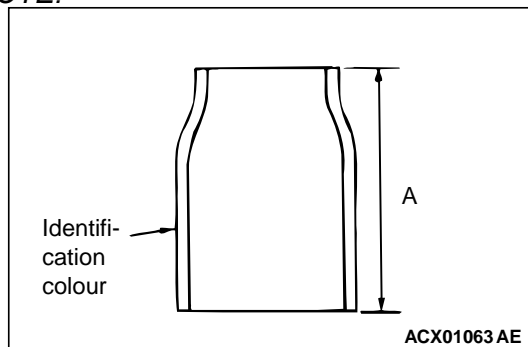

When selecting the drive pinion front shims, if the number of shims is large, reduce the number of shims to a minimum by selecting the drive pinion spacers.
Select the drive pinion spacer from the following two types.

Height of drive pinion spacer (A) mm	Identification colour
57.08	Red
57.72	—

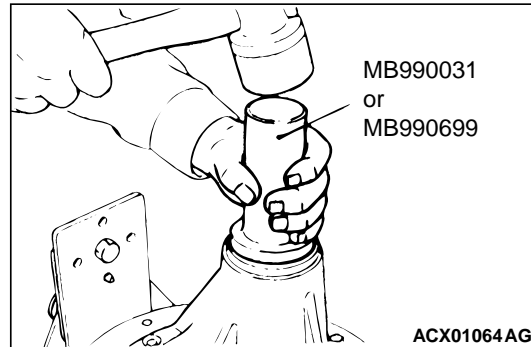

- Remove the companion flange and drive pinion again. Then insert the drive pinion carrier front bearing inner race into the differential carrier. Use special tool oil seal installer (MB990031 or MB990699) to press-fit the drive pinion oil seal.

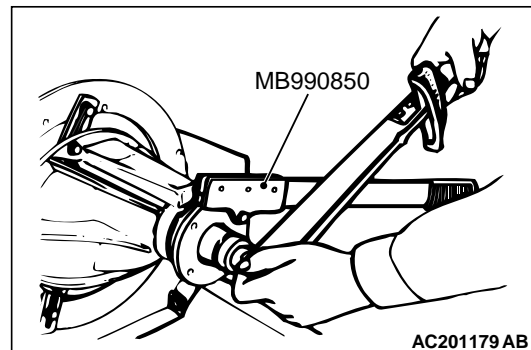

- Install the drive pinion assembly and companion flange with the mating marks properly aligned. Tighten the companion flange self-locking nut to the specified torque while holding the companion flange with special tool.

Tightening torque: 186 ± 29 N·m

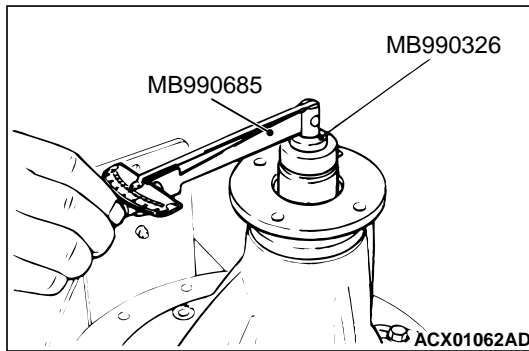

- Use special tools to measure the drive pinion turning torque (with drive pinion oil seal) to verify that the drive pinion turning torque complies with the standard value.

Standard value:

Bearing division	Companion flange lubrication	Turning torque
New	None (with anti-rust agent)	1.0 – 1.3 N·m
	Gear oil applied	0.5 – 0.6 N·m

- If the turning torque is not within the standard value, check the tightening torque of the companion flange self-locking nut, and the installation of the oil seal.

>>F<< DIFFERENTIAL GEAR BACKLASH ADJUSTMENT

Adjust the differential gear backlash by the following procedure:

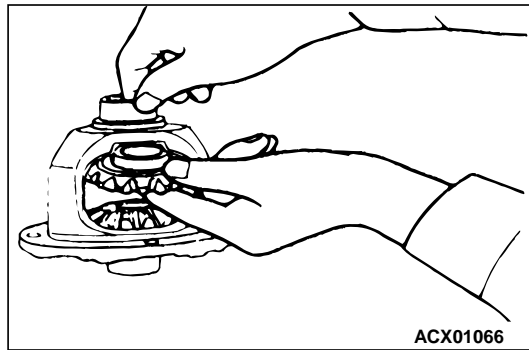

- Assemble the side gears, side gear spacers, pinion gears, and pinion washers into the differential case.
- Temporarily install the pinion shaft.

NOTE: Do not assemble the lock pin yet.

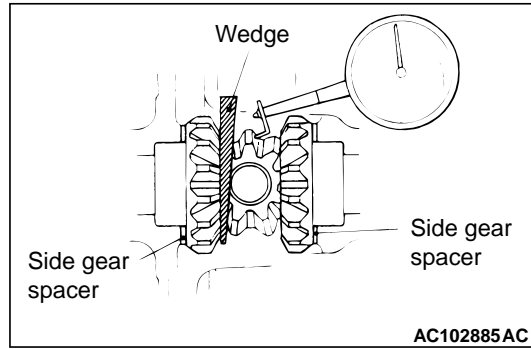

- Insert a wedge between the side gear and the pinion shaft to lock the side gear.
- While locking the side gear with the wedge, measure the differential gear backlash with a dial indicator on the pinion gear.

Measure by the same procedure for the other pinion gear.

Standard value: 0 – 0.076 mm

Limit: 0.2 mm

- If the backlash exceeds the limit value, adjust it by replacing the side gear spacers.
- If adjustment is not possible, replace the side gears and pinion gears as a set.
- Check that the backlash is within the limit value and that the differential gear turns smoothly.

>>G<< LOCK PIN INSTALLATION

- Align the pinion shaft lock pin hole with the differential case lock pin hole, and drive in the lock pin.

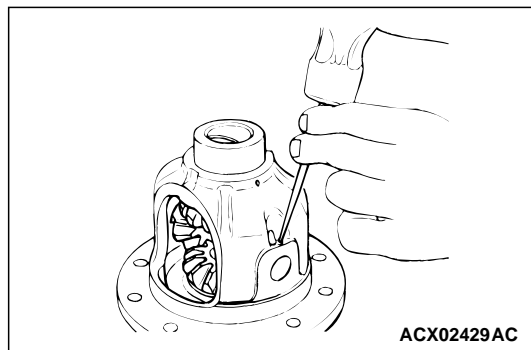

- Stake the lock pin with a punch on both sides.

>>H<< DRIVE GEAR INSTALLATION

1. Clean the drive gear attaching bolts.

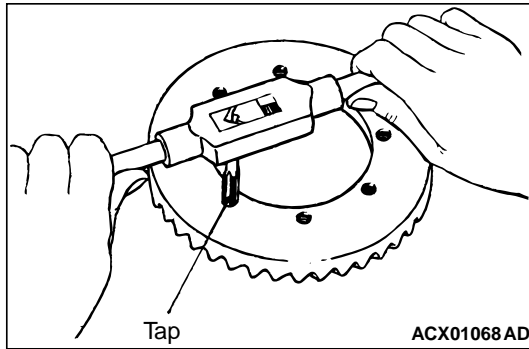

2. Remove the adhesive adhered to the threaded holes of the drive gear by turning the tap (M10 x 1.25). Clean the threaded holes by applying compressed air.

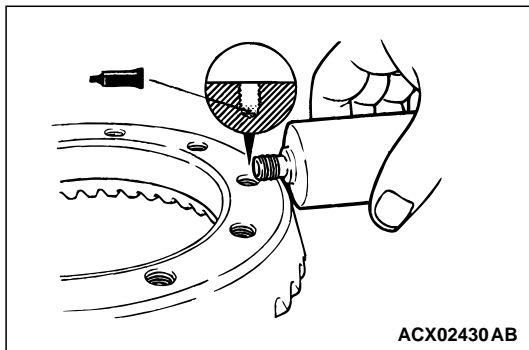

3. Apply the specified sealant to the threaded holes of the drive gear.

Specified sealant: 3M stud locking 4170 or equivalent

4. Install the drive gear onto the differential case with the mating marks properly aligned. Tighten the drive gear attaching bolts to the specified torque in a diagonal sequence.

Tightening torque: 84 ± 4 N·m

>>I<< DIFFERENTIAL SIDE BEARING INNER RACE INSTALLATION

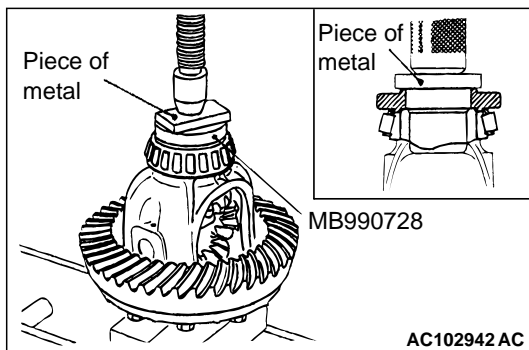

Use special tool bearing installer (MB990728) to press-fit the differential side bearing inner races into the differential case.

>>J<< BEARING CAP INSTALLATION/FINAL DRIVE GEAR BACKLASH ADJUSTMENT

Adjust the final drive gear backlash by the following procedure:

1. Assemble the differential case with the side bearing outer race to the differential carrier.

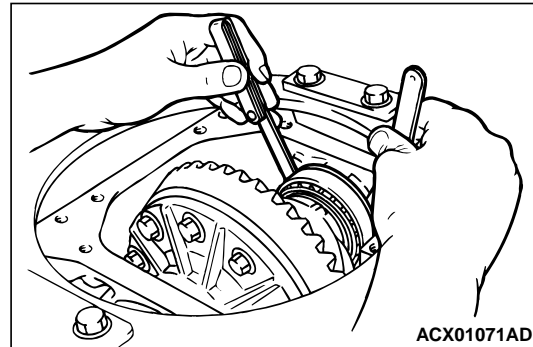

2. Press the differential case to one side to measure the clearance of the side bearing outer race and the differential carrier.
3. Select two pairs of side bearing spacers. Determine the thickness by adding 1/2 of the clearance to the pre-load 0.05mm.

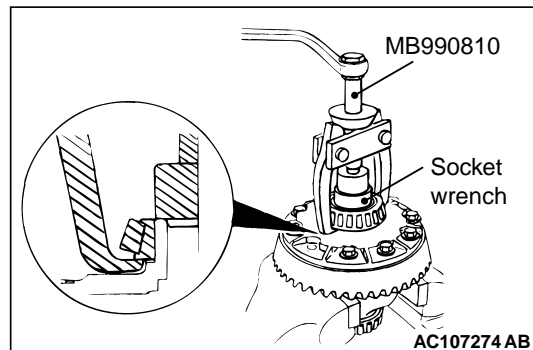

4. Remove the side bearing by using special tool side bearing puller (MB990810).

NOTE: Hook the claws of special tool with the side bearing inner race by using the notches (two areas) of the differential case side.

5. Assemble the selected side bearing spacers to each side.

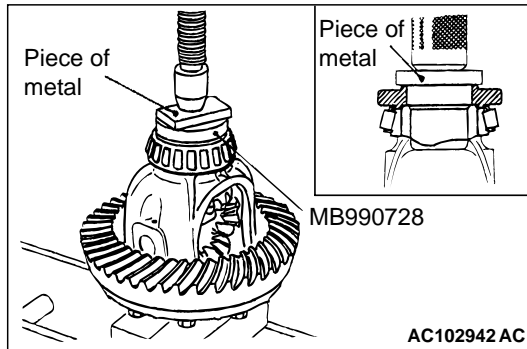

6. Use special tool bearing installer (MB990728) to press-fit the side bearing inner race into the differential case. After installing the outer race, assemble the differential case to the differential carrier.
7. Align the mating marks of differential carrier and the bearing cap with each other and tighten the bearing cap attaching bolts to the specified torque.

Tightening torque: 37 ± 2 N·m

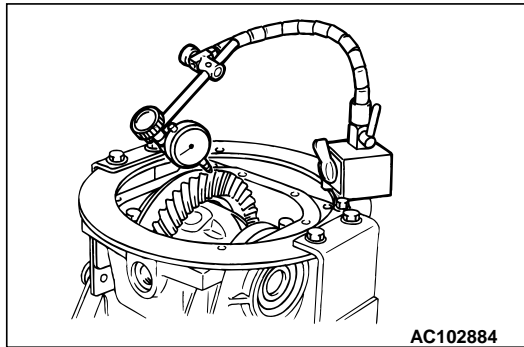

8. Measure the final drive gear backlash at four points or more on the circumference of the drive gear.

Standard value: 0.11 – 0.16 mm

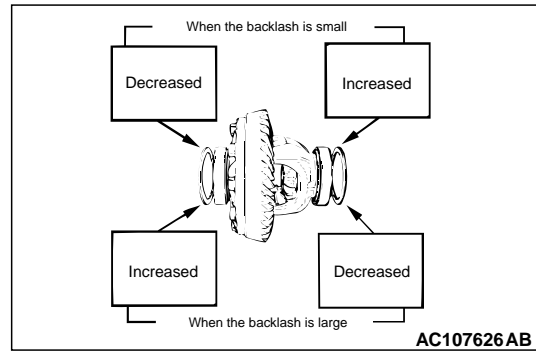

9. If the backlash is not within the standard value, move the side bearing spacer as shown in the illustration to adjust the backlash.

NOTE: The increment of side bearing spacer must be the same as the decreased amount.

10. Inspect the tooth condition at the final drive gear and replace if required. (Refer to P.27B-19).

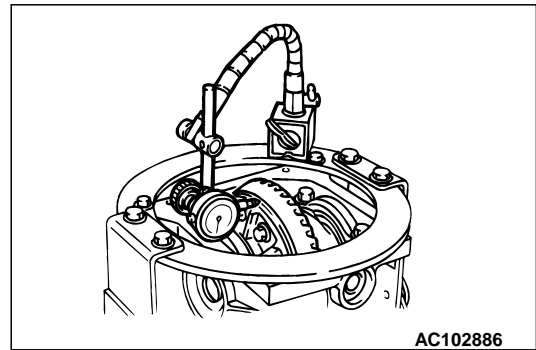

11. Measure the drive gear runout.

Limit: 0.05 mm

12. If drive gear runout exceeds the limit, remove the differential case and then the drive gears, moving them to different positions and reinstall them.
13. If adjustment is not possible, replace the differential case or drive gear and drive pinion as a set.