

## GROUP 17

# ENGINE AND EMISSION CONTROL

## CONTENTS

<b>ENGINE CONTROL</b> .....	<b>17-3</b>	ADJUSTMENT <4G63> .....	17-5
<b>GENERAL INFORMATION</b> .....	17-3	ACCELERATOR CABLE CHECK AND ADJUSTMENT <4G69> .....	17-5
<b>SERVICE SPECIFICATIONS</b> .....	17-3	<b>ACCELERATOR CABLE AND PEDAL &lt;4G63&gt;</b> .....	17-6
<b>TROUBLESHOOTING</b> .....	17-3	REMOVAL AND INSTALLATION.....	17-6
INTRODUCTION TO ENGINE CONTROL SYSTEM DIAGNOSIS .....	17-3	<b>ACCELERATOR CABLE AND PEDAL &lt;4G69&gt;</b> .....	17-7
ENGINE CONTROL SYSTEM DIAGNOSTIC TROUBLESHOOTING STRATEGY ...	17-3	REMOVAL AND INSTALLATION.....	17-7
SYMPTOM CHART .....	17-3	<b>ACCELERATOR PEDAL POSITION SENSOR &lt;4G69&gt;</b> .....	17-9
SYMPTOM PROCEDURES .....	17-3	REMOVAL AND INSTALLATION.....	17-9
<b>ON-VEHICLE SERVICE</b> .....	17-5		
ACCELERATOR CABLE CHECK AND			

Continued on next page

<b>EMISSION CONTROL &lt;MPI&gt; ..</b>	<b>17-10</b>	GENERAL INFORMATION (EVAPORATIVE EMISSION CONTROL SYSTEM) .....	17-17
<b>GENERAL INFORMATION .....</b>	17-10	COMPONENT LOCATION (EVAPORATIVE EMISSION CONTROL SYSTEM) .....	17-18
<b>EMISSION CONTROL DEVICE REFERENCE TABLE .....</b>	17-10	PURGE CONTROL SYSTEM CHECK ..	17-18
<b>SERVICE SPECIFICATIONS.....</b>	17-11	PURGE PORT VACUUM CHECK .....	17-19
<b>SPECIAL TOOL.....</b>	17-11	PURGE CONTROL SOLENOID VALVE CHECK.....	17-20
<b>VACUUM HOSE.....</b>	17-12	CANISTER REMOVAL AND INSTALLATION .....	17-21
VACUUM HOSE PIPING DIAGRAM ...	17-12		
VACUUM CIRCUIT DIAGRAM .....	17-13	<b>EXHAUST GAS RECIRCULATION (EGR) SYSTEM .....</b>	17-22
VACUUM HOSE CHECK.....	17-14	GENERAL INFORMATION (EGR SYSTEM) .....	17-22
VACUUM HOSE INSTALLATION .....	17-14	COMPONENT LOCATION (EGR SYSTEM) .....	17-23
<b>CRANKCASE EMISSION CONTROL SYSTEM.....</b>	17-15	EGR SYSTEM CHECK <4G63> .....	17-24
GENERAL INFORMATION (CRANKCASE EMISSION CONTROL SYSTEM) .....	17-15	EGR PORT VACUUM CHECK<4G63> .	17-24
COMPONENT LOCATION (CRANKCASE EMISSION CONTROL SYSTEM) .....	17-15	EGR VALVE CHECK <4G63> .....	17-24
POSITIVE CRANKCASE VENTILATION SYSTEM CHECK.....	17-16	EGR CONTROL SOLENOID VALVE CHECK <4G63>.....	17-25
POSITIVE CRANKCASE VENTILATION (PCV) VALVE CHECK.....	17-16	EGR VALVE (STEPPER MOTOR) CHECK <4G69>.....	17-25
<b>EVAPORATIVE EMISSION CONTROL SYSTEM.....</b>	17-17	EXHAUST GAS RECIRCULATION (EGR) VALVE REMOVAL AND INSTALLATION <4G63>.....	17-27
		EXHAUST GAS RECIRCULATION (EGR) VALVE REMOVAL AND INSTALLATION <4G69>.....	17-28
		<b>CATALYTIC CONVERTER .....</b>	17-29
		REMOVAL AND INSTALLATION.....	17-29

## ENGINE CONTROL

### GENERAL INFORMATION

A cable-type accelerator mechanical suspended-type pedal has been adopted.

M1171000100329

### SERVICE SPECIFICATIONS

M1171000300099

Items	Standard value	
Accelerator cable play mm	1.0 – 2.0	
Engine idle speed r/min	4G63	750 ± 50
	4G69	700 ± 100

### TROUBLESHOOTING

#### INTRODUCTION TO ENGINE CONTROL SYSTEM DIAGNOSIS

M1171002000287

If there is a malfunction in the engine control system, the accelerator cable, accelerator pedal or throttle lever may be faulty.

#### ENGINE CONTROL SYSTEM DIAGNOSTIC TROUBLESHOOTING STRATEGY

M1171002100314

Use these steps to plan your diagnostic strategy.

SYMPTOM	INSPECTION PROCEDURE	REFERENCE PAGE
Throttle valve will not fully open or close <4G63>	1	P.17-3
Throttle valve will not fully open or close <4G69>	2	P.17-4
Accelerator pedal operation is not smooth (over acceleration)	3	P.17-4

If you follow them carefully, you will be sure that you have exhausted most of the possible ways to find an engine control system fault.

1. Gather information from the customer.
2. Verify that the condition described by the customer exists.
3. Find the malfunction by following the Symptom Chart.
4. Verify that the malfunction is eliminated.

#### SYMPTOM CHART

M1171002200322

### SYMPTOM PROCEDURES

#### INSPECTION PROCEDURE 1: Throttle Valve will not Fully Open or Close <4G63>

#### DIAGNOSIS

##### STEP 1. Check the accelerator cable adjustment.

**Q: Is the accelerator cable properly adjusted?**

**YES :** Go to Step 2 .

**NO :** Adjust the accelerator cable (Refer to P.17-5). Then go to Step 3 .

##### STEP 2. Check the throttle valve.

Check that the throttle lever of the throttle body assembly moves smoothly by moving it by hand.

**Q: Does the throttle lever of the throttle body assembly move smoothly?**

**YES :** Go to Step 3 .

**NO :** Cleaning the throttle body (Refer to GROUP 13A, On-vehicle Service P.13A-324), or replace the throttle body assembly (Refer to GROUP 13A, Throttle Body P.13A-340). Then go to Step 3 .

##### STEP 3. Retest the system.

**Q: Does the throttle valve fully open and close?**

**YES :** The procedure is complete.

**NO :** Return to Step 1 .

**INSPECTION PROCEDURE 2: Throttle Valve will not Fully Open or Close <4G69>****DIAGNOSIS****STEP 1. Check the accelerator cable adjustment.**

**Q: Is the accelerator cable properly adjusted?**

**YES :** Go to Step 2 .

**NO :** Adjust the accelerator cable (Refer to [P.17-5](#)). Then go to Step 5 .

**STEP 2. Check the accelerator pedal position sensor assembly.**

Check that the lever of the accelerator pedal position sensor assembly moves smoothly by moving it by hand.

**Q: Does the lever of the accelerator pedal position sensor assembly move smoothly?**

**YES :** Go to Step 3 .

**NO :** Replace the accelerator pedal position sensor assembly (Refer to [P.17-9](#)). Then go to Step 5 .

**STEP 3. Check the accelerator pedal position sensor assembly.**

Refer to GROUP 13B, On-vehicle Service [P.13B-431](#).

**Q: Is the accelerator pedal position sensor assembly normally?**

**YES :** Go to Step 4 .

**NO :** Replace the accelerator pedal position sensor assembly (Refer to [P.17-9](#)). Then go to Step 5 .

**STEP 4. Check the Throttle valve (Throttle valve control servo).**

Refer to GROUP 13B, On-vehicle Service [P.13B-436](#)

**Q: Is the throttle valve control servo normally?**

**YES :** Go to Step 5 .

**NO :** Cleaning the throttle body (Refer to GROUP 13B, On-vehicle Service [P.13B-425](#)), or replace the throttle body assembly (Refer to GROUP 13B, Throttle Body [P.13B-438](#)). Then go to Step 5 .

**STEP 5. Retest the system.**

**Q: Does the throttle valve fully open and close?**

**YES :** The procedure is complete.

**NO :** Return to Step 1 .

**INSPECTION PROCEDURE 3: Accelerator Pedal Operation is not Smooth (Over Acceleration)****DIAGNOSIS****STEP 1. Check the accelerator pedal.**

**Q: Is the accelerator pedal loose?**

**YES :** Tighten the fasteners. Then go to Step 4 .

**NO :** Go to Step 2 .

**STEP 2. Check the accelerator cable wiring.**

**Q: Is the accelerator cable routing bent sharply?**

**YES :** Correct the cable routing Then go to Step 4

**NO :** Go to Step 3 .

**STEP 3. Check the accelerator cable lubricant.**

**Q: Is the accelerator cable lubricated sufficiently?**

**YES :** Go to Step 4 .

**NO :** Refill or replace the lubricant. Then go to Step 4 .

**STEP 4. Retest the system.**

**Q: Does the accelerator pedal work normally?**

**YES :** The procedure is complete.

**NO :** Return to Step 1 .

## ON-VEHICLE SERVICE

### ACCELERATOR CABLE CHECK AND ADJUSTMENT <4G63>

M1171000900347

1. Turn A/C and lights OFF. Inspect and adjust at no load.
2. Warm engine until stabilized at idle.
3. Confirm idle speed is at standard value.

**Standard value: 750 ± 50 r/min**

4. Stop engine. [ignition switch: LOCK (OFF) position].
5. Confirm there are no sharp bends in the accelerator cable.
6. Check the inner cable for correct slack.

**Standard value: 1.0 – 2.0 mm**

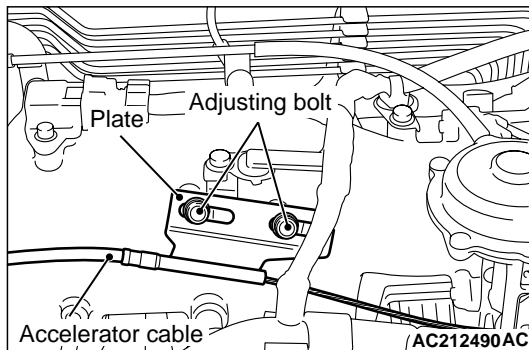

7. If there is too much slack or no slack, adjust play by the following procedures.
  - (1) Loosen the adjusting bolts to release the cable.
  - (2) Move the plate until the inner cable play is at the standard value, and then tighten the adjusting bolts.

- (3) After adjusting, check that the throttle lever is touching the stopper.

### ACCELERATOR CABLE CHECK AND ADJUSTMENT <4G69>

M1171000900358

1. Turn A/C and lights OFF. Inspect and adjust at no load.
2. Warm engine until stabilized at idle.
3. Confirm idle speed is at standard value.

**Standard value: 700 ± 100 r/min**

4. Stop engine. [ignition switch: LOCK (OFF) position].
5. Confirm there are no sharp bends in the accelerator cable.
6. Check the inner cable for correct slack.

**Standard value: 1.0 – 2.0 mm**

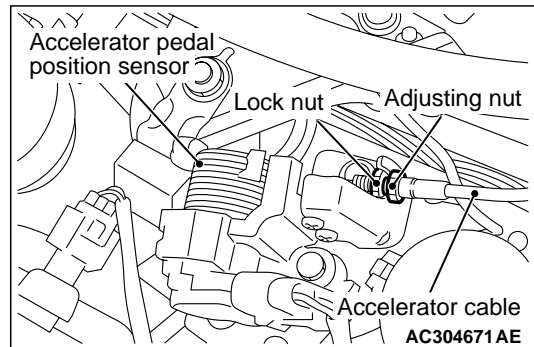

7. If there is too much slack or no slack, adjust play by the following procedures.
  - (1) Loosen the lock nut and adjusting nut to release the cable.
  - (2) Tighten the adjusting nut until the inner cable play is at the standard value, and then tighten the lock nut.

ACCELERATOR CABLE AND PEDAL  
<4G63>

## REMOVAL AND INSTALLATION

M1171001200404

**Post-installation Operation**

Adjusting the Accelerator Cable (Refer to P.17-5).

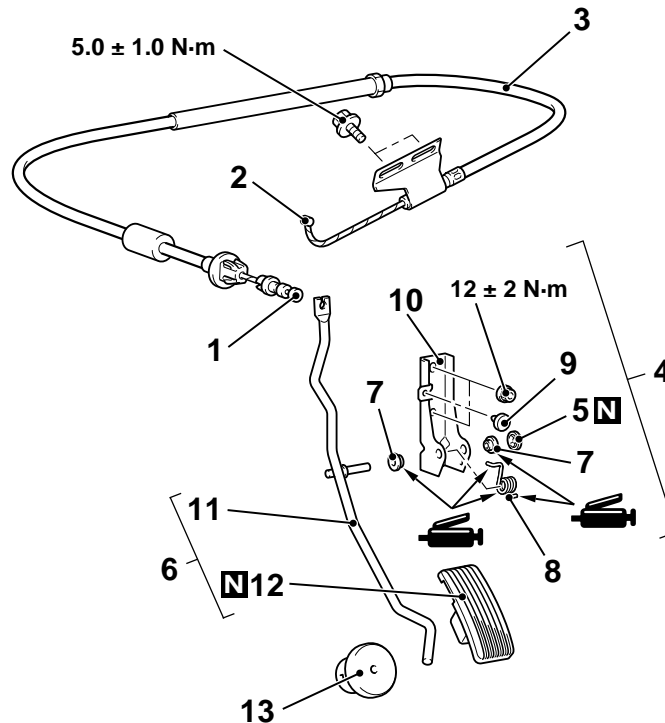

AC309483AB

**Accelerator cable assembly  
removal steps**

1. Inner cable connection (Accelerator pedal side)
2. Inner cable connection (Throttle body side)
3. Accelerator cable assembly

**Accelerator pedal assembly  
removal steps**

1. Inner cable connection (Accelerator pedal side)
4. Accelerator pedal assembly
5. Push-on spring nut
6. Accelerator arm and accelerator pedal pad assembly
7. Bushing
8. Spring
9. Stopper

**Accelerator pedal assembly  
removal steps (Continued)**

10. Accelerator pedal bracket
11. Accelerator arm
- >>A<< 12. Accelerator pedal pad
13. Accelerator pedal stopper

**INSTALLATION SERVICE POINT****>>A<< PEDAL PAD INSTALLATION****CAUTION**

To prevent damages to the Pedal Pad, warm the thumb area of the Pedal Pad with a dryer, etc. prior to assembling it.

*NOTE: If it is difficult to assemble, apply soapy water to the thumb area to enhance the assembling process.*

## ACCELERATOR CABLE AND PEDAL <4G69>

### REMOVAL AND INSTALLATION

M1171001200415

#### <L.H. drive vehicles>

#### Post-installation Operation

Adjusting the Accelerator Cable (Refer to P.17-5).

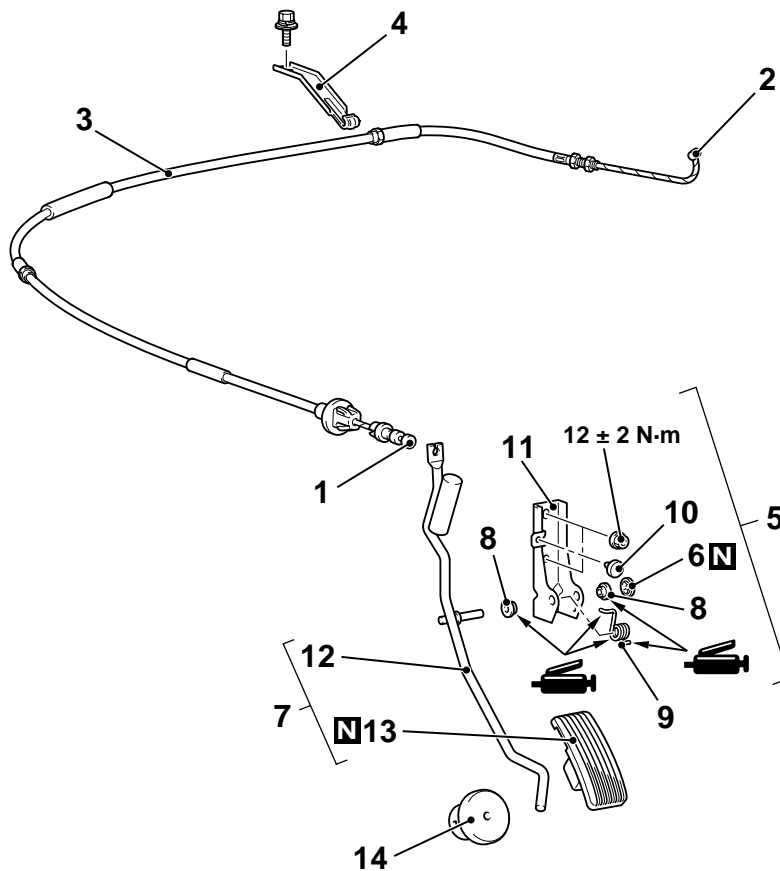

AC309484AB

#### Accelerator cable assembly removal steps

1. Inner cable connection (Accelerator pedal side)
2. Inner cable connection (Accelerator pedal position sensor side)
3. Accelerator cable assembly
4. Accelerator cable bracket

#### Accelerator pedal assembly removal steps

1. Inner cable connection (Accelerator pedal side)
5. Accelerator pedal assembly

#### Accelerator pedal assembly removal steps (Continued)

6. Push-on spring nut
  7. Accelerator arm and accelerator pedal pad assembly
  8. Bushing
  9. Spring
  10. Stopper
  11. Accelerator pedal bracket
  12. Accelerator arm
  13. Accelerator pedal pad
  14. Accelerator pedal stopper
- >>A<<

## &lt;R.H. drive vehicles&gt;

**Post-installation Operation**

Adjusting the Accelerator Cable (Refer to P.17-5.)

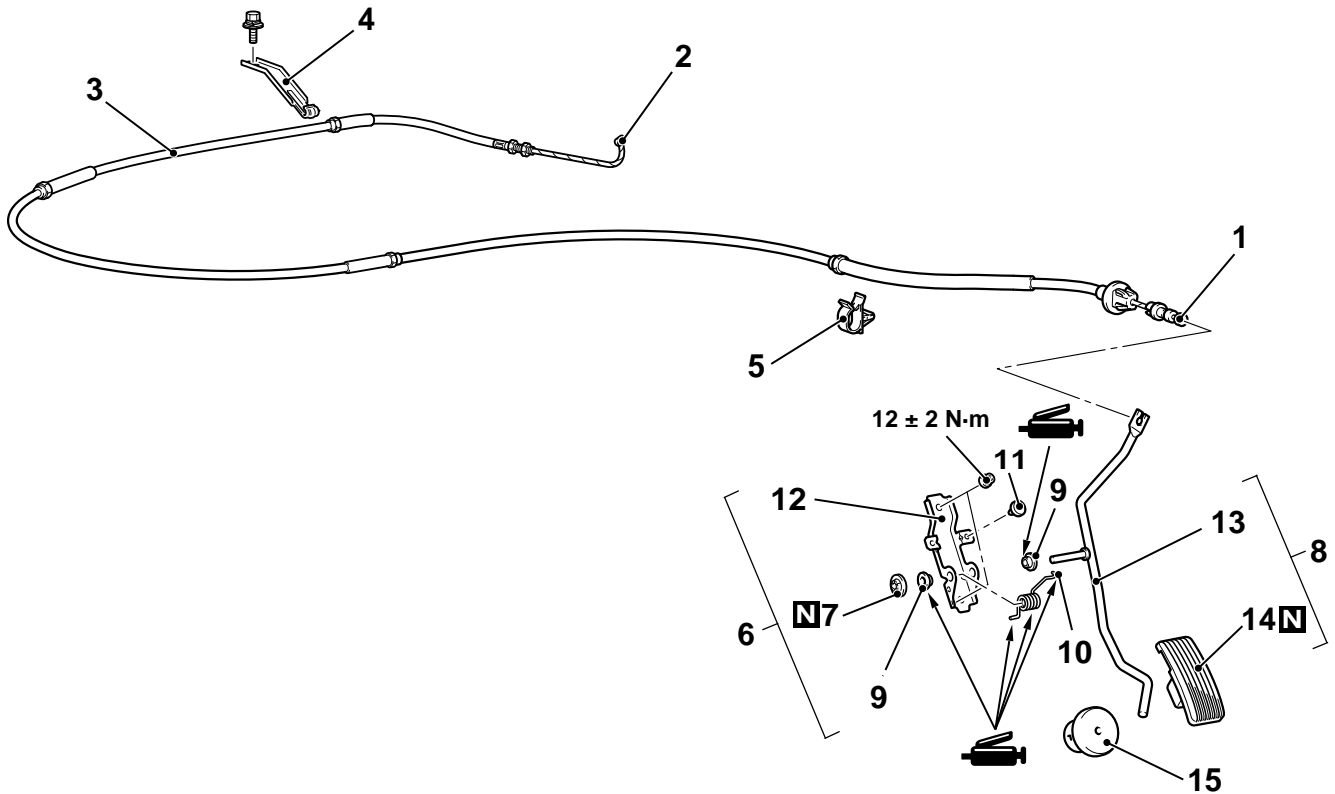

AC309485AB

**Accelerator cable assembly  
removal steps**

1. Inner cable connection (Accelerator pedal side)
2. Inner cable connection (Accelerator pedal position sensor side)
3. Accelerator cable assembly
4. Accelerator cable bracket
5. Accelerator cable clip

**Accelerator pedal assembly  
removal steps**

1. Inner cable connection (Accelerator pedal side)
6. Accelerator pedal assembly
7. Push-on spring nut
8. Accelerator arm and accelerator pedal pad assembly
9. Bushing
10. Spring

**Accelerator pedal assembly  
removal steps (Continued)**

11. Stopper
12. Accelerator pedal bracket
13. Accelerator arm
- >>A<< 14. Accelerator pedal pad
15. Accelerator pedal stopper

**INSTALLATION SERVICE POINT****>>A<< PEDAL PAD INSTALLATION****⚠ CAUTION**

To prevent damages to the Pedal Pad, warm the thumb area of the Pedal Pad with a dryer, etc. prior to assembling it.

*NOTE: If it is difficult to assemble, apply soapy water to the thumb area to enhance the assembling process.*

## ACCELERATOR PEDAL POSITION SENSOR <4G69>

### REMOVAL AND INSTALLATION

M1171001800053

#### Post-installation Operation

Adjusting the Accelerator Cable (Refer to P.17-5).

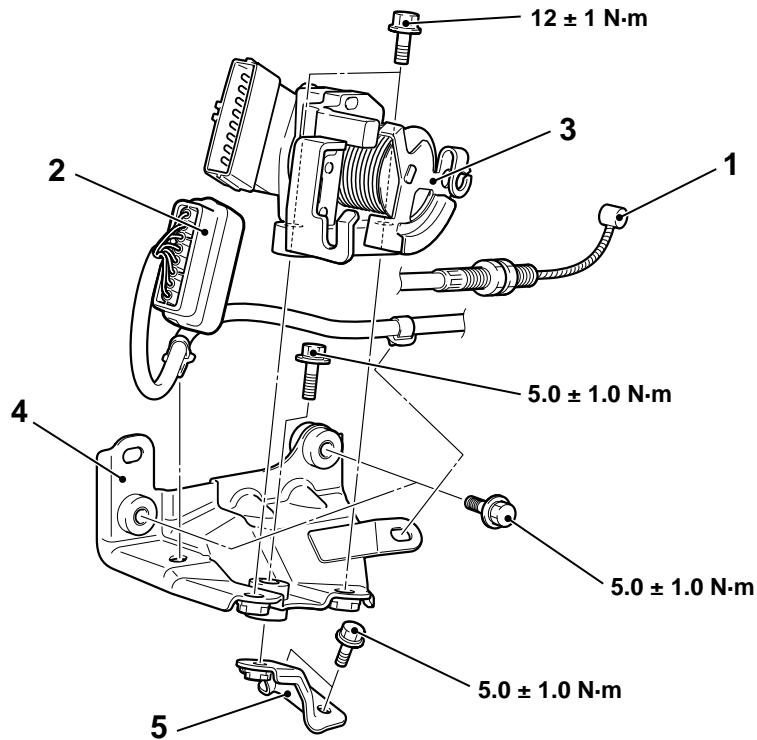

AC305408AC

#### Removal steps

1. Inner cable connection (Accelerator pedal position sensor side)
2. Accelerator pedal position sensor connector
3. Accelerator pedal position sensor assembly

#### Removal steps (Continued)

4. Accelerator pedal position sensor bracket
5. Accelerator pedal position sensor bracket support

**EMISSION CONTROL <MPI>****GENERAL INFORMATION**

The emission control system consists of the following subsystems:

M1173000100466

- Crankcase emission control system
- Evaporative emission control system
- Exhaust emission control system

Items	Name	Specification
Crankcase emission control system	Positive crankcase ventilation (PCV) valve	Variable flow type (Purpose: HC reduction)
Evaporative emission control system	Canister Purge control solenoid valve	Equipped Duty cycle type solenoid valve (Purpose: HC reduction)
Exhaust emission control system	Air-fuel ratio control device - MPI system	Oxygen sensor feedback type (Purpose: CO, HC, NOx reduction)
	Exhaust gas recirculation system <4G63> • EGR valve • EGR control solenoid valve	Equipped  Single type Duty cycle type solenoid valve (Purpose: NOx reduction)
	Exhaust gas recirculation system <4G69> • EGR valve	Equipped  Steeper motor type (Purpose: NOx reduction)
	Catalytic converter	Monolith type (Purpose: CO, HC, NOx reduction)

**EMISSION CONTROL DEVICE  
REFERENCE TABLE**

M1173006600157

Related parts	Crankcase emission control system	Evaporative emission control system	Air/fuel ratio control system	Catalytic converter	Exhaust gas recirculation system
PCV valve	×				
Purge control solenoid valve		×			
MPI system component		×	×		
Catalytic converter				×	
EGR valve <4G63>					×
EGR control solenoid valve <4G63>					×
EGR valve (Steeper moter) <4G69>					×

**SERVICE SPECIFICATIONS**

M1173000300363

Items	Standard value
Purge control solenoid valve coil resistance (at 20°C) Ω	30 – 34
EGR control solenoid valve coil resistance (at 20°C) Ω <4G63>	29 – 35
EGR valve coil resistance (at 20°C) Ω <4G69>	20 – 24

**SPECIAL TOOL**

M1173000600201

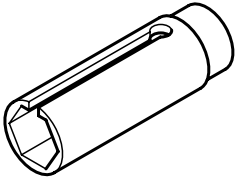
Tool	Number	Name	Use
	MD991658	Test harness	EGR valve (Steeper moter) CHECK
	MD998770	Oxygen sensor wrench	Removal and installation of oxygen sensor

VACUUM HOSE

VACUUM HOSE PIPING DIAGRAM

M1173000900439

<4G63>

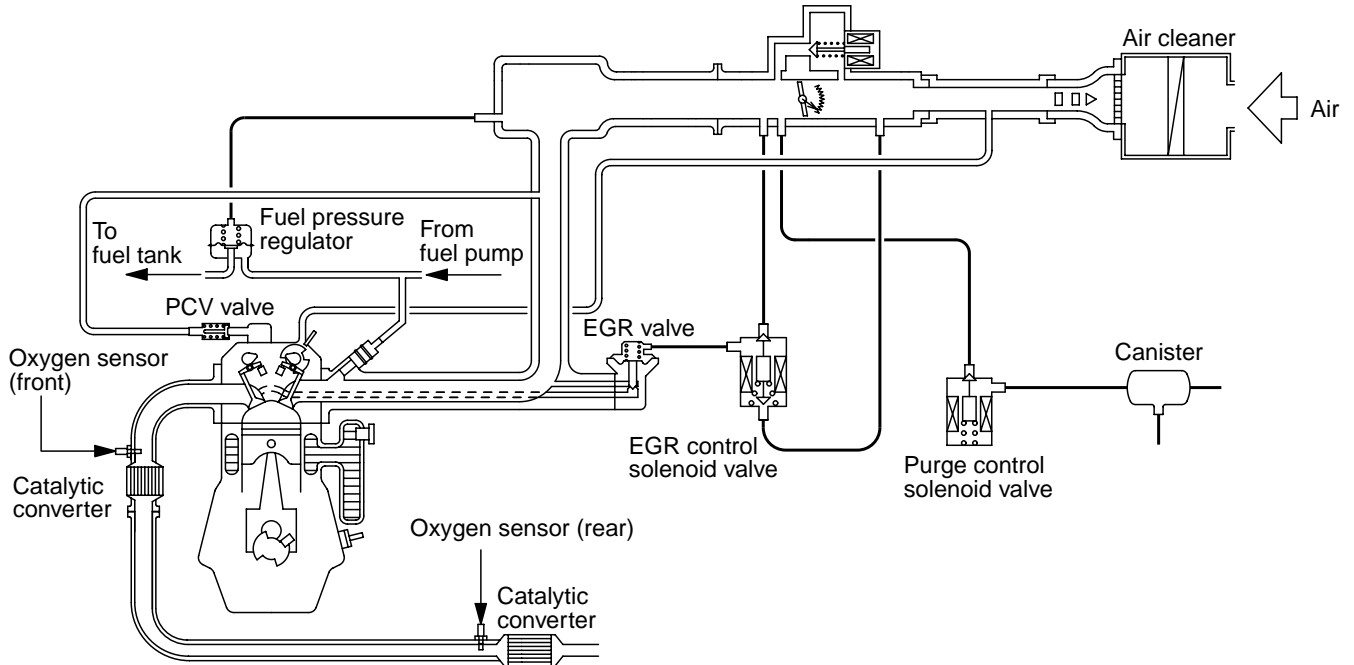

AK204364 AB

<4G69>

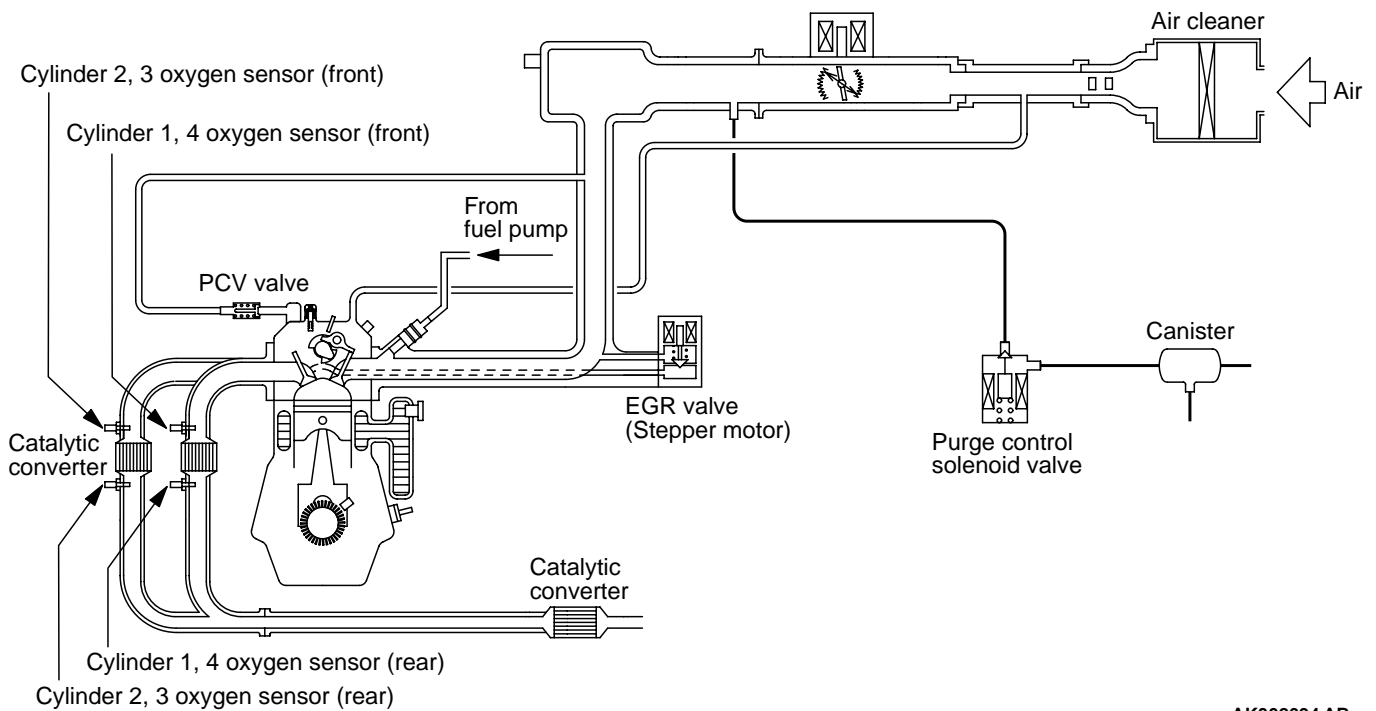

AK302694 AB

VACUUM CIRCUIT DIAGRAM

M1173007100285

<4G63>

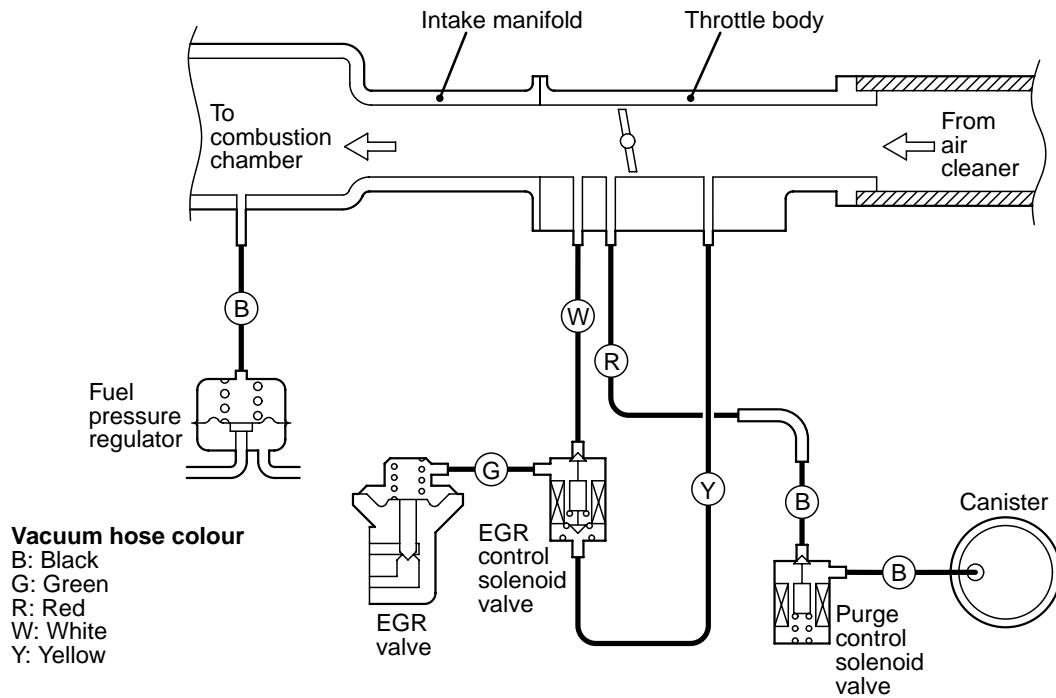

AK201210 AC

<4G69>

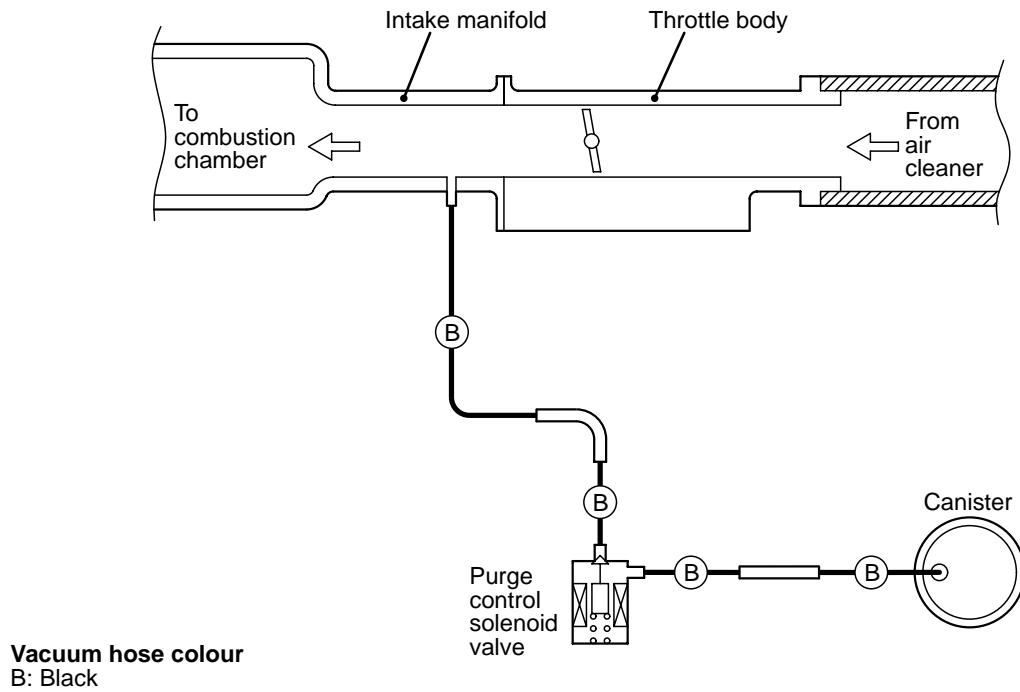

AK302823 AB

**VACUUM HOSE CHECK**

M1173007300160

1. Using the piping diagram as a guide, check to be sure that the vacuum hoses are correctly connected.
2. Check the connection condition of the vacuum hoses, (removed, loose, etc.) and check to be sure that there are no bends or damage.

**VACUUM HOSE INSTALLATION**

M1173007200118

1. When connecting the vacuum hoses, they should be securely inserted onto the nipples.
2. Connect the hoses correctly, using the vacuum hose piping diagram as a guide.

## CRANKCASE EMISSION CONTROL SYSTEM

### GENERAL INFORMATION (CRANKCASE EMISSION CONTROL SYSTEM)

M1173005000334

The crankcase emission control system prevents blow-by gases from escaping inside the crankcase into the atmosphere.

Fresh air is sent from the air cleaner into the crankcase through the breather hose.

The air becomes mixed with the blow-by gases inside the crankcase.

The blow-by gas inside the crankcase is drawn into the intake manifold through the positive crankcase ventilation (PCV) valve.

The PCV valve lifts the plunger according to the intake manifold vacuum so as to regulate the flow of blow-by gas properly.

In other words, the blow-by gas flow is regulated during low load engine operation to maintain engine stability, while the flow is increased during high load operation to improve the ventilation performance.

### SYSTEM DIAGRAM

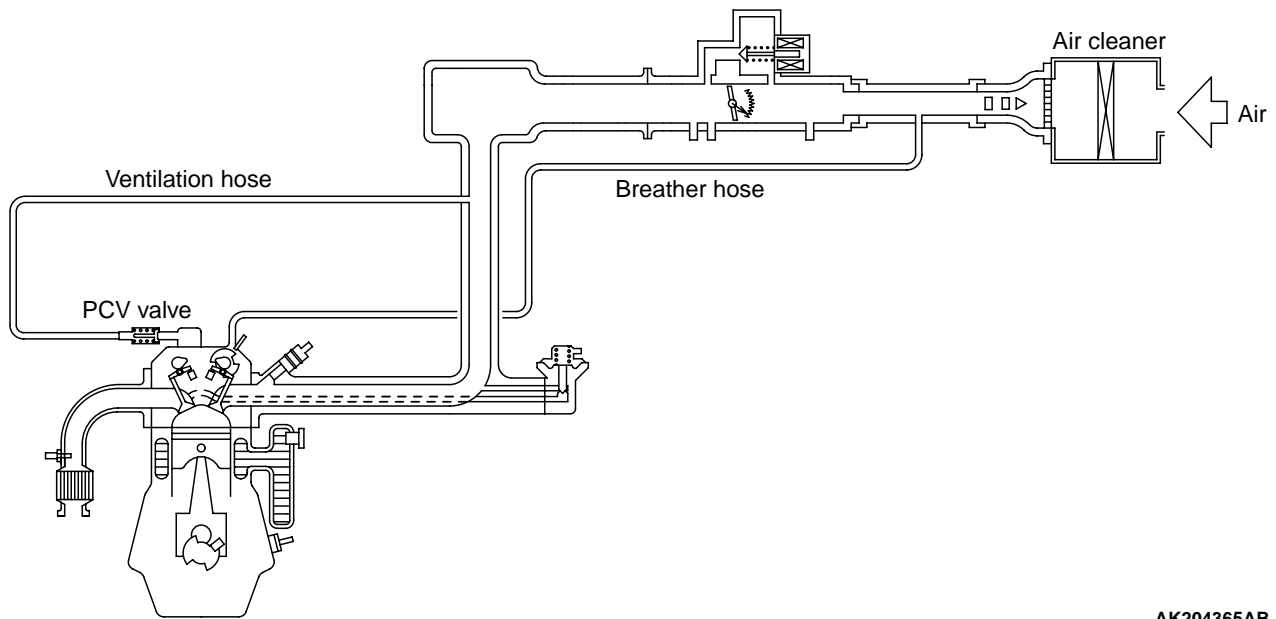

AK204365AB

### COMPONENT LOCATION (CRANKCASE EMISSION CONTROL SYSTEM)

M1173007400242

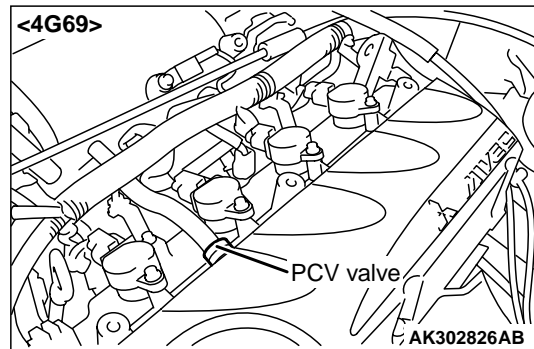
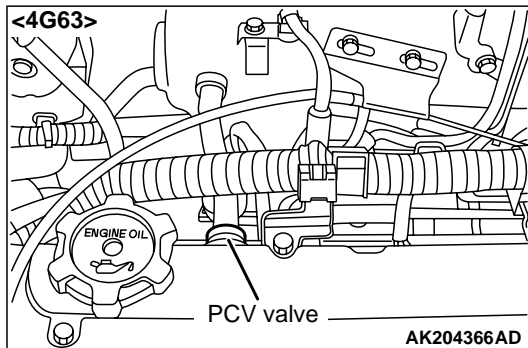

**POSITIVE CRANKCASE VENTILATION  
SYSTEM CHECK**

M1173001100221

1. Remove the ventilation hose from the PCV valve.
2. Remove the PCV valve from the rocker cover.
3. Reinstall the PCV valve at the ventilation hose.
4. Start the engine and run at idle.

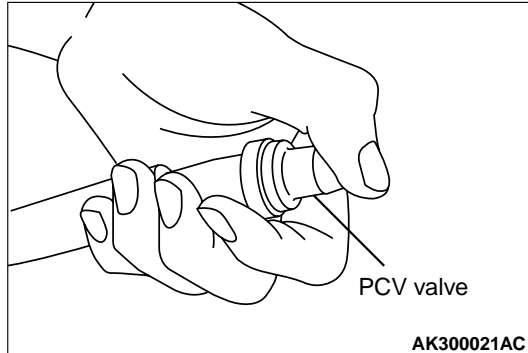

5. Place a finger at the opening of the PCV valve and check that vacuum of the intake manifold is felt.

*NOTE: At this moment, the plunger in the PCV valve moves back and forth.*

6. If vacuum is not felt, clean the PCV valve or replace it.

**POSITIVE CRANKCASE VENTILATION  
(PCV) VALVE CHECK**

M1173001200217

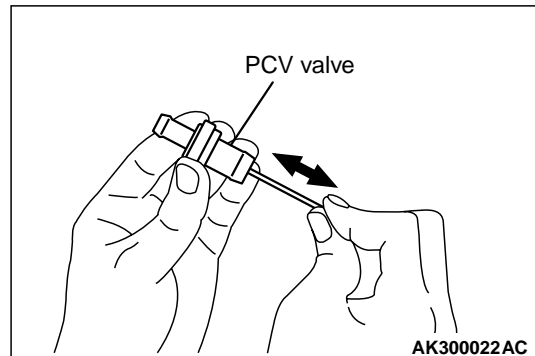

1. Insert a thin rod into the PCV valve from the side shown in the illustration (rocker cover installation side), and move the rod back and forth to check that the plunger moves.
2. If the plunger does not move, there is a clogging in the PCV valve. In this case, clean or replace the PCV valve.

## EVAPORATIVE EMISSION CONTROL SYSTEM

### GENERAL INFORMATION (EVAPORATIVE EMISSION CONTROL SYSTEM)

M1173005100427

The evaporative emission control system prevents fuel vapours generated in the fuel tank from escaping into the atmosphere.

Fuel vapours from the fuel tank flow through the fuel tank pressure control valve and vapour pipe/hose to be stored temporarily in the canister.

When driving the vehicle, fuel vapours stored in the canister flow through the purge control solenoid valve and purge port and go into the intake manifold to be sent to the combustion chamber.

When the engine coolant temperature is low or when the intake air quantity is small (when the engine is at idle, for example), the engine control unit turns the purge solenoid off to shut off the fuel vapour flow to the intake manifold.

This does not only insure the driveability when the engine is cold or running under low load but also stabilize the emission level.

### SYSTEM DIAGRAM

<4G63>

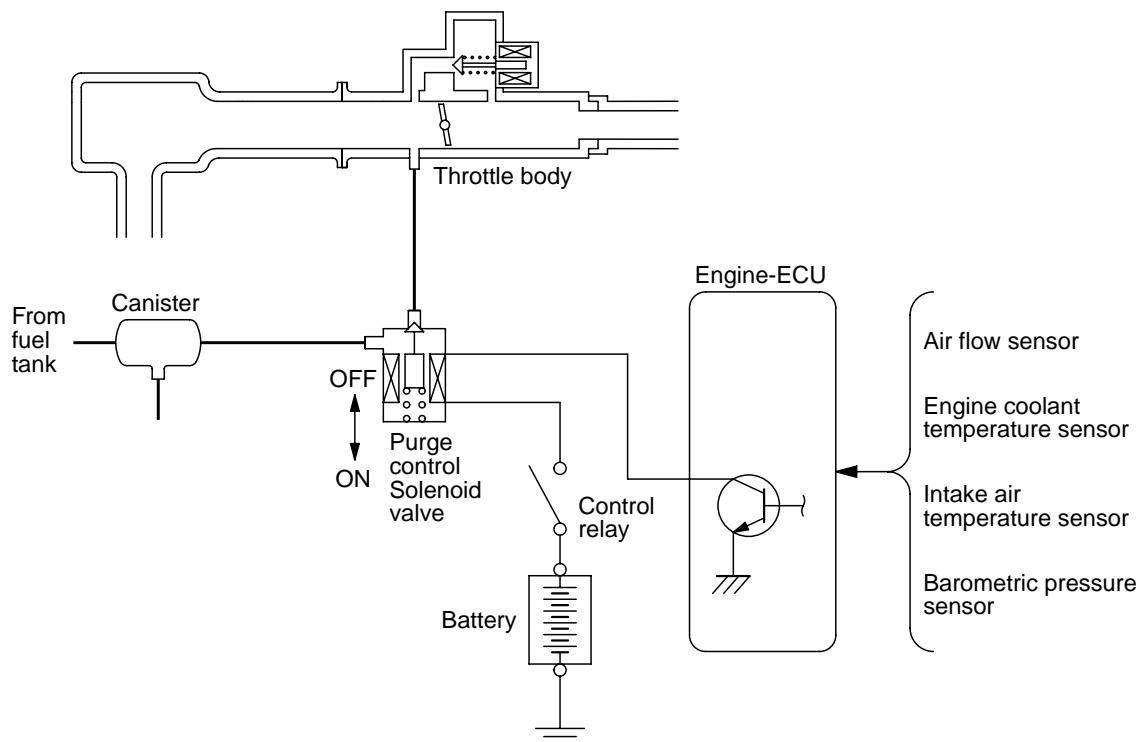

<4G69>

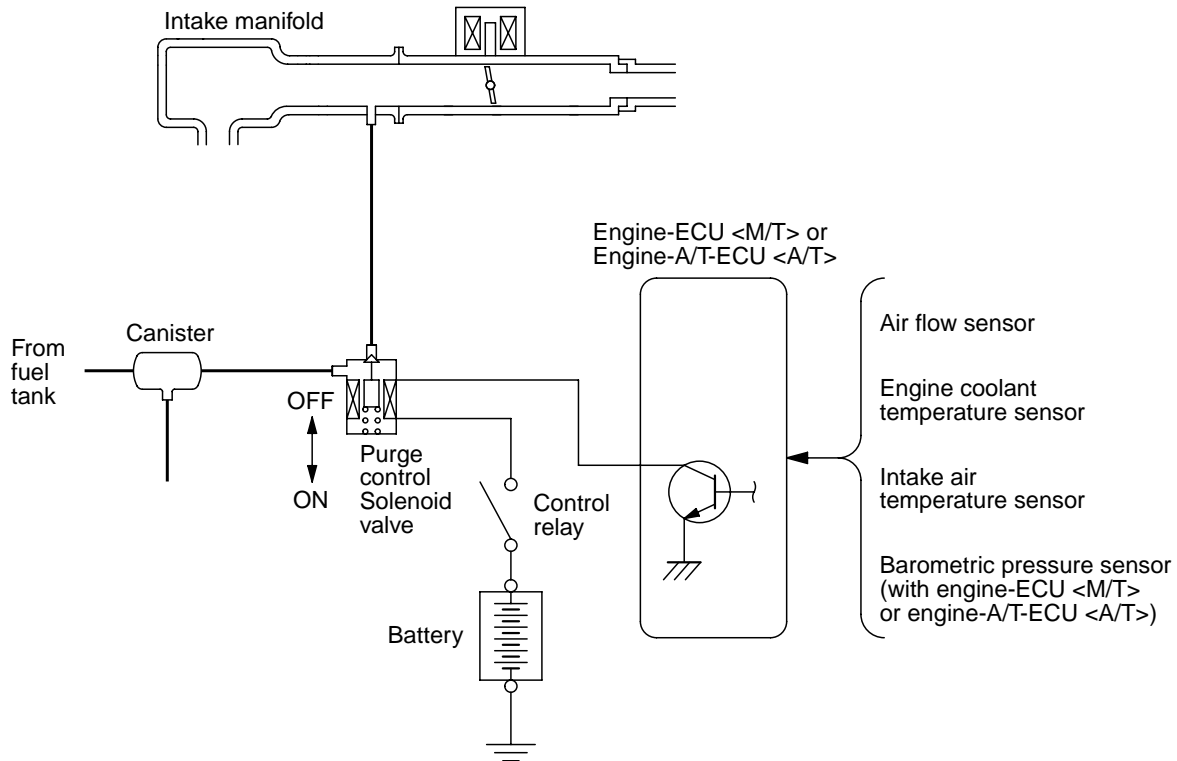

AK302829AB

**COMPONENT LOCATION (EVAPORATIVE EMISSION CONTROL SYSTEM)**

M1173007500238

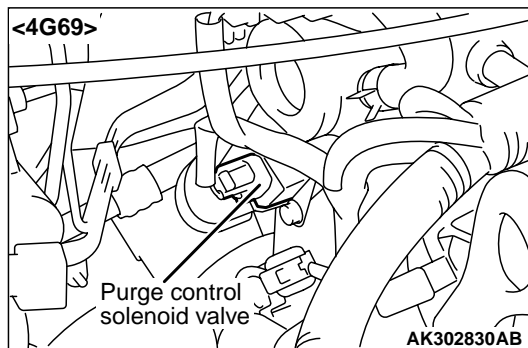
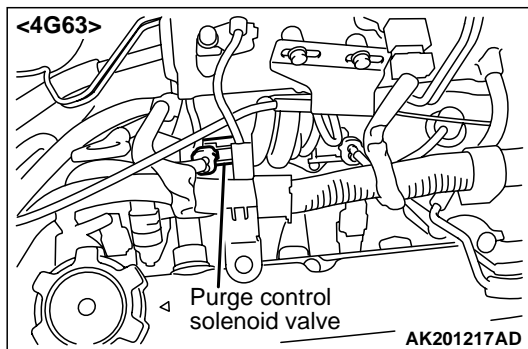

**PURGE CONTROL SYSTEM CHECK**

M1173001400318

<4G63>

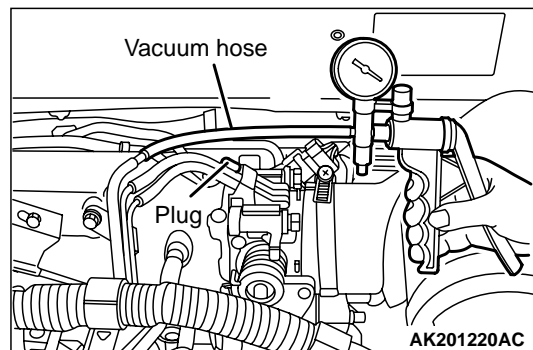

1. Disconnect the vacuum hose (red stripe) from throttle body and connect it to a hand vacuum pump.
2. Plug the nipple from which the vacuum hose was removed.
3. When the engine is cold or hot, apply a vacuum of 53 kPa, and check the condition of the vacuum.

**When engine is cold**  
(Engine coolant temperature: 40°C or less)

Engine condition	Normal condition
At idle	Vacuum is maintained.
3,000 r/min	

**When engine is hot**  
(Engine coolant temperature: 80°C or higher)

Engine condition	Normal condition
At idle	Vacuum is maintained.
3,000 r/min (within 3 minutes after engine starts)	Vacuum will leak.

<4G69>

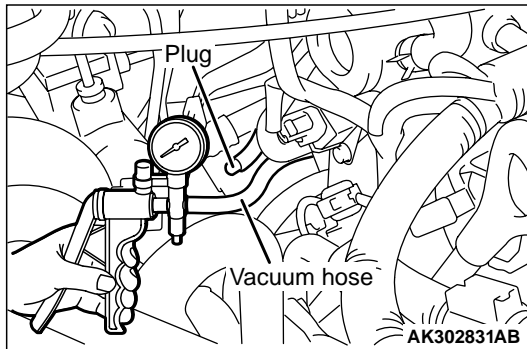

1. Disconnect the vacuum hose (between purge control solenoid valve and intake manifold) from purge control solenoid valve and connect a hand vacuum pump to the nipple.
2. Plug the vacuum hose.
3. When the engine is cold or hot, apply a vacuum of 53 kPa, and check the condition of the vacuum.

**When engine is cold**  
(Engine coolant temperature: 40°C or less)

Engine condition	Normal condition
At idle	Vacuum is maintained.
3,000 r/min	

**When engine is hot**  
(Engine coolant temperature: 80°C or higher)

Engine condition	Normal condition
At idle	Vacuum will leak.
3,000 r/min (within 3 minutes after engine starts)	

**PURGE PORT VACUUM CHECK**

M1173001500188

<4G63>

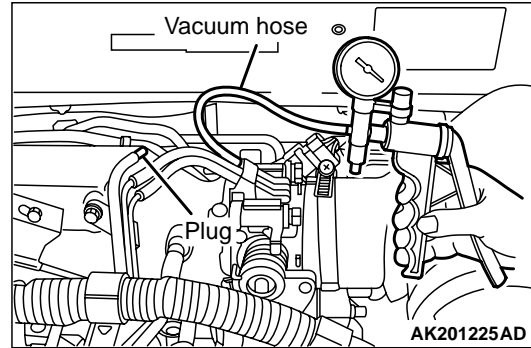

1. Disconnect the vacuum hose (red stripe) from the throttle body and connect a hand vacuum pump to the nipple.
2. Plug the vacuum hose (red stripe).

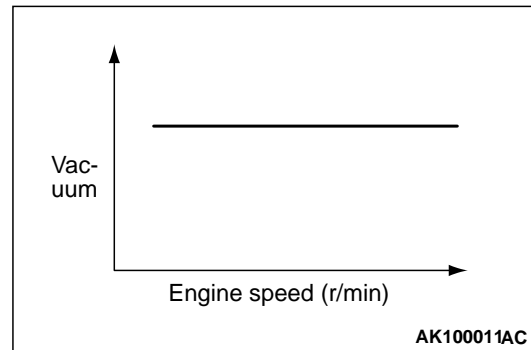

3. Start the engine.
4. Check that a fairly constant negative pressure is generated regardless of the engine speed.
5. If no negative pressure is generated, the port is probably blocked and should be cleaned.

&lt;4G69&gt;

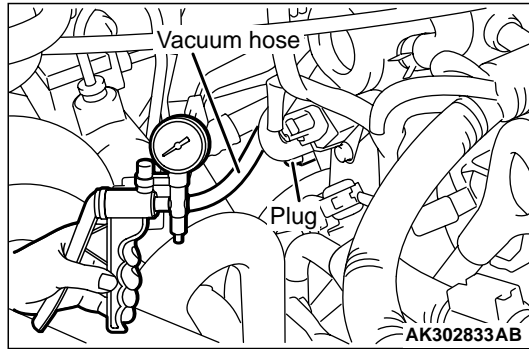

1. Disconnect the vacuum hose (between purge control solenoid valve and intake manifold) from the purge control solenoid valve and connect it to a hand vacuum pump.
2. Plug the nipple from which the vacuum hose was removed.

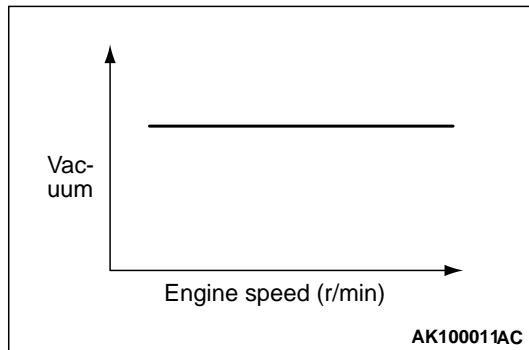

3. Start the engine.
4. Check that a fairly constant negative pressure is generated regardless of the engine speed.
5. If no negative pressure is generated, the port is probably blocked and should be cleaned.

## PURGE CONTROL SOLENOID VALVE CHECK

M1173001700234

*NOTE: When disconnecting the vacuum hose, always make a mark so that it can be reconnected at original position.*

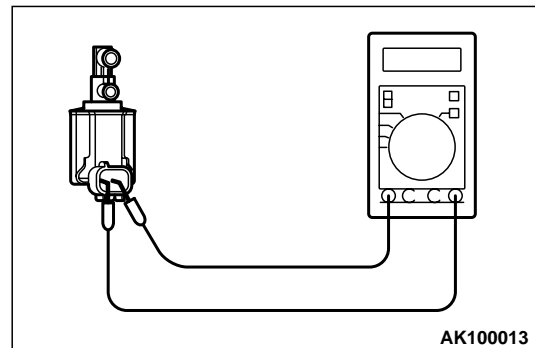
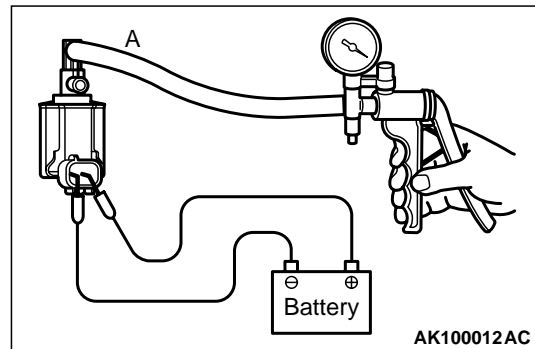

1. Disconnect the vacuum hose from the solenoid valve.
2. Disconnect the harness connector.
3. Connect a hand vacuum pump to nipple (A) of the solenoid valve (refer to the illustration at left).
4. Check airtightness by applying a vacuum with voltage applied directly from the battery to the purge control solenoid valve and without applying voltage.

Battery voltage	Normal condition
Applied	Vacuum leaks
Not applied	Vacuum maintained

5. Measure the resistance between the terminals of the solenoid valve.

**Standard value: 30 – 34 Ω (at 20°C)**

**CANISTER REMOVAL AND INSTALLATION**

M1173004200175

**Pre-removal and Post-installation Operation**

Air cleaner cover and air intake hose removal and installation  
(4G63: Refer to GROUP 15 - Air cleaner P.15-3) (4G69:  
Refer to GROUP 15 - Air cleaner P.15-4).

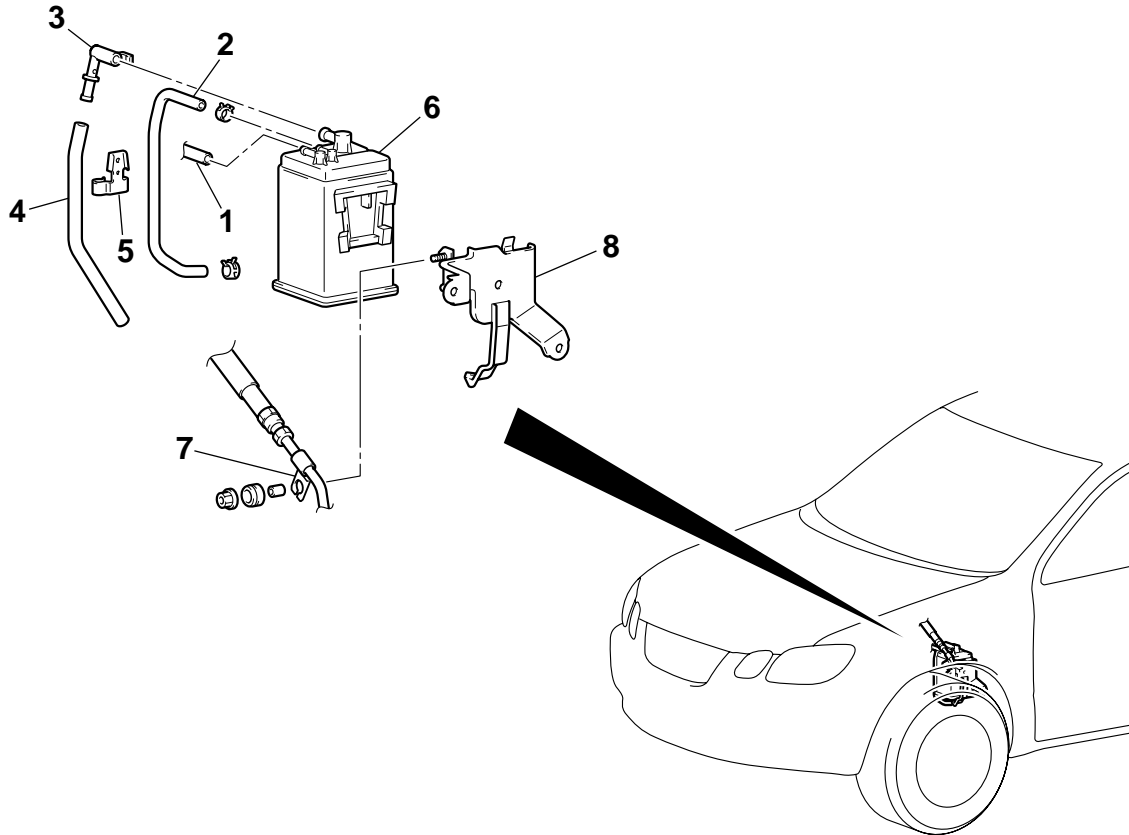

AC212494 AB

**Removal steps**

1. Purge hose connection
2. Vapour hose
3. Vent connector
4. Vapour hose
5. Hose clamp

**Removal steps (Continued)**

6. Canister
7. Fuel high-pressure hose clamp  
<4G63>
8. Canister bracket

**EXHAUST GAS RECIRCULATION  
(EGR) SYSTEM****GENERAL INFORMATION (EGR SYSTEM)**

M1173005200349

The exhaust gas recirculation (EGR) system lowers the nitrogen oxide (NOx) emission level. When the air/fuel mixture combustion temperature is high, a large quantity of nitrogen oxides (NOx) is generated in the combustion chamber. Therefore, this system recirculates part of emission gas from the exhaust port of the cylinder head to the combustion chamber through the intake manifold to decrease the air/fuel mixture combustion temperature, resulting in reduction of NOx.

**SYSTEM DIAGRAM**

&lt;4G63&gt;

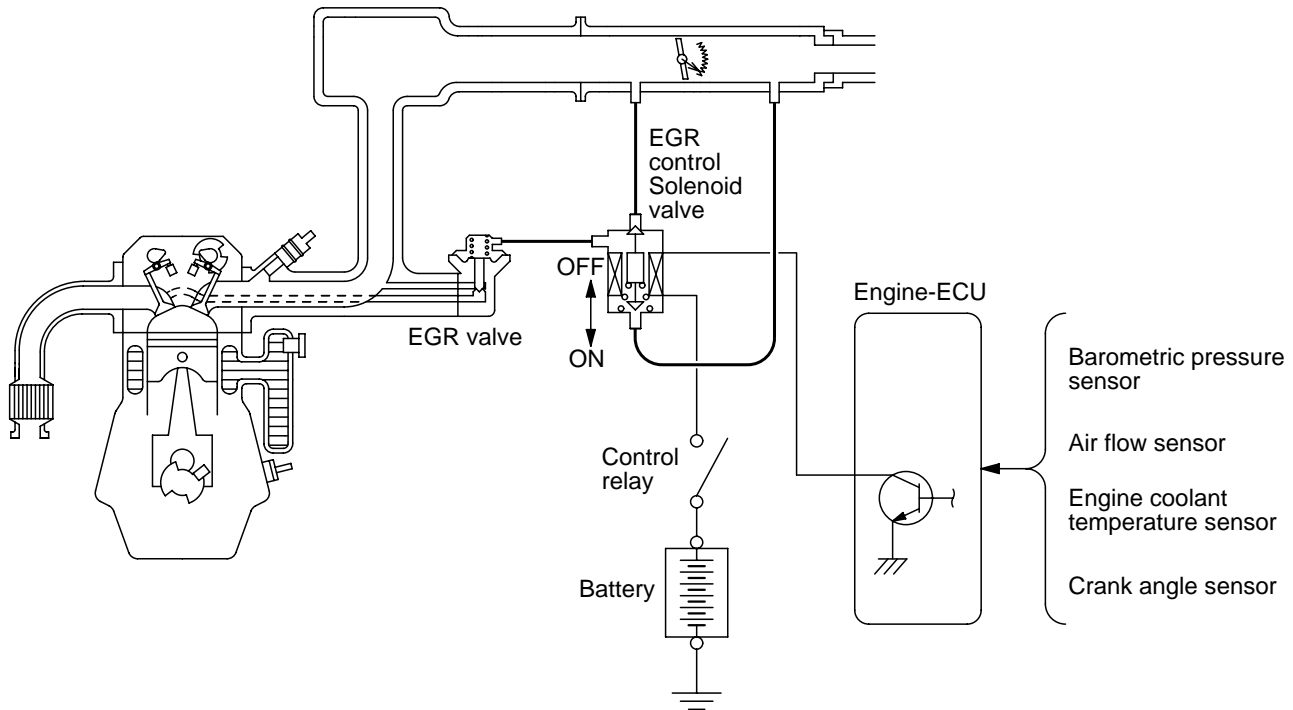

The EGR flow rate is controlled by the EGR valve so as not to decrease the driveability.

**OPERATION**

The EGR valve is being closed and does not recirculate exhaust gases under one of the following conditions.

Otherwise, the EGR valve is opened and recirculates exhaust gases.

- The engine coolant temperature is low.
- The engine is at idle.
- The throttle valve is widely opened.

<4G69>

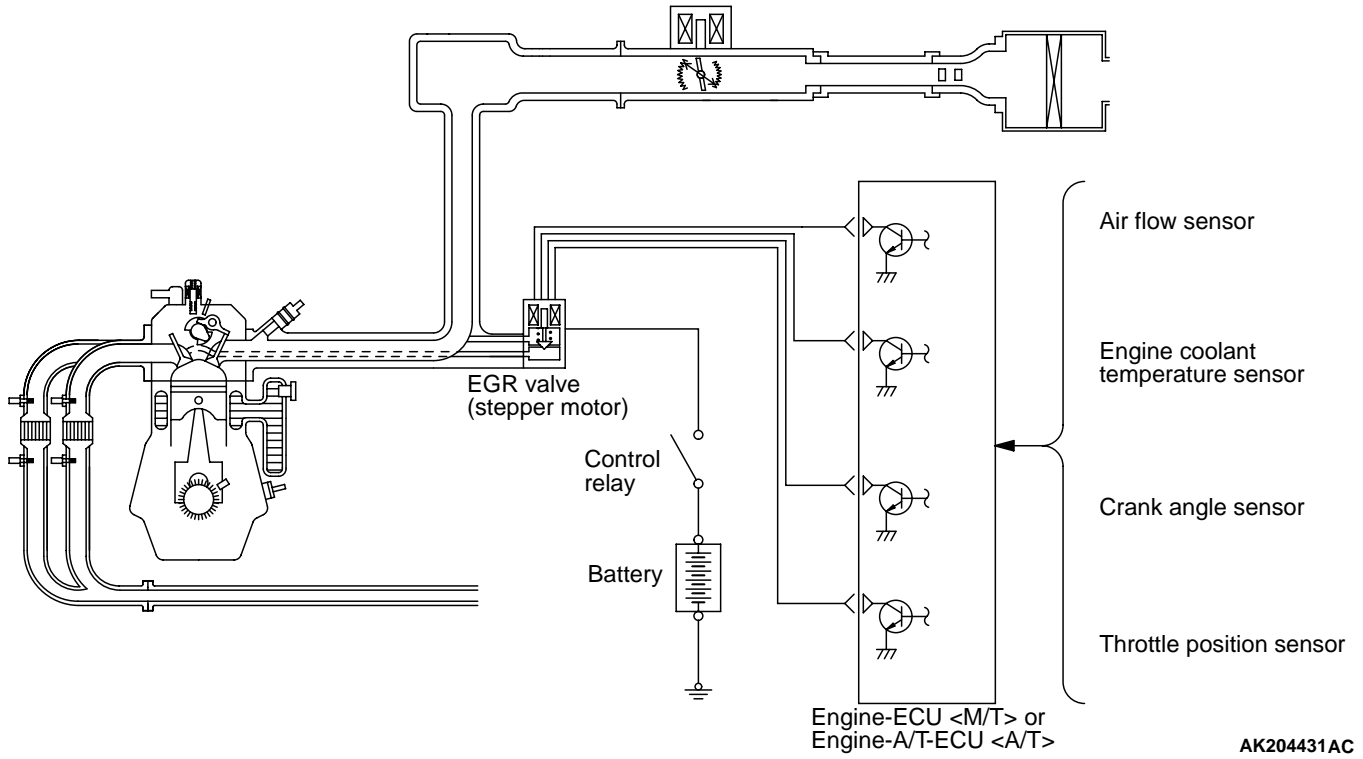

COMPONENT LOCATION (EGR SYSTEM)

M1173007600246

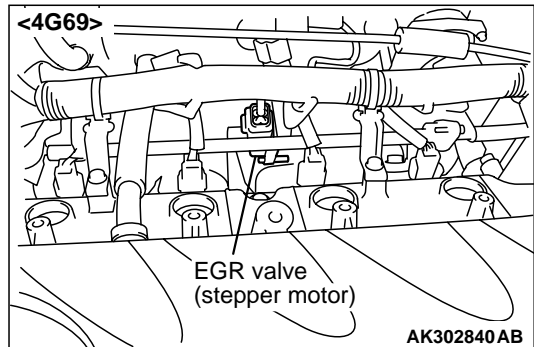
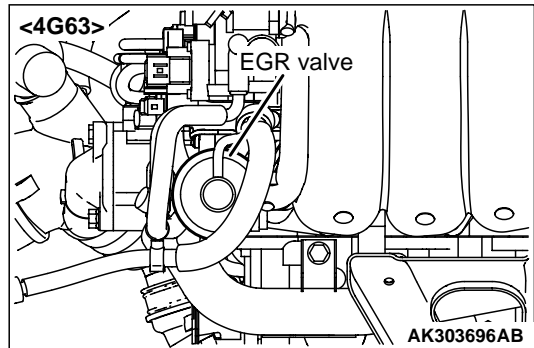
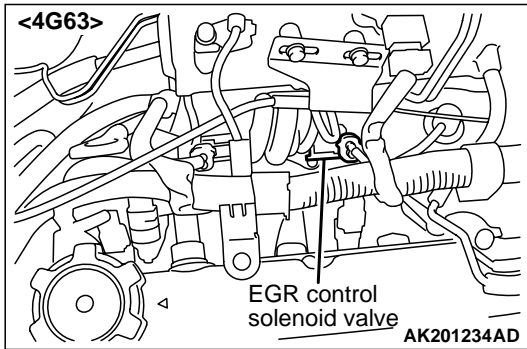

**EGR SYSTEM CHECK <4G63>**

M1173002600360

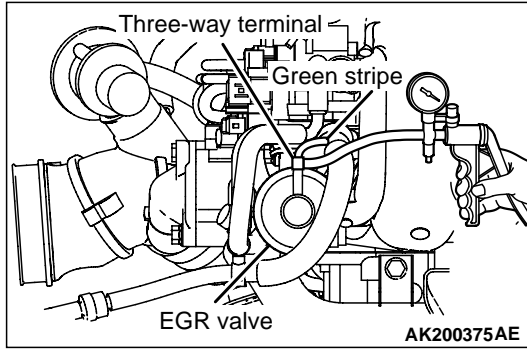

1. Disconnect the vacuum hose (Green stripe) from the EGR valve, and then connect a hand vacuum pump via the three-way terminal.
2. When the engine is hot or cold, check the condition of vacuum by racing the engine.

**When engine is cold  
(Engine coolant temperature: 20°C or less)**

Throttle valve	Normal vacuum condition
Open quickly	No vacuum will generate (the same as barometric pressure.)

**When engine is hot  
(Engine coolant temperature: 80°C or higher)**

Throttle valve	Normal vacuum condition
Open quickly	It will momentarily rise over 13 kPa

3. Disconnect the three-way terminal.

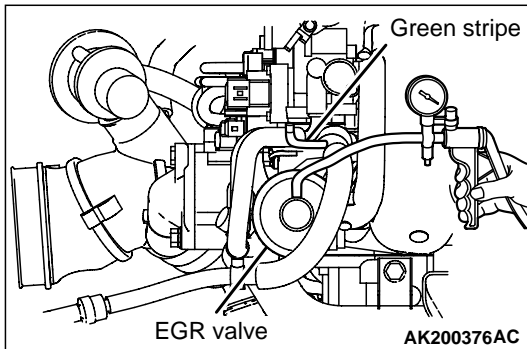

4. Connect the hand vacuum pump to the EGR valve nipple.
5. Check whether the engine stalls or the idling is unstable when a vacuum of 30 kPa or higher is applied during idling.

**EGR PORT VACUUM CHECK<4G63>**

M1173002900178

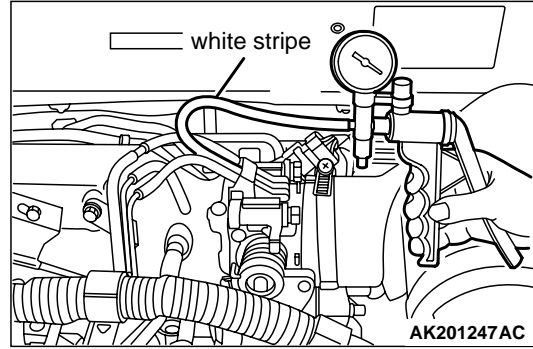

1. Disconnect the vacuum hose (White stripe) from the throttle body EGR vacuum nipple and connect a hand vacuum pump to the nipple.
2. Plug the vacuum hose (White stripe).

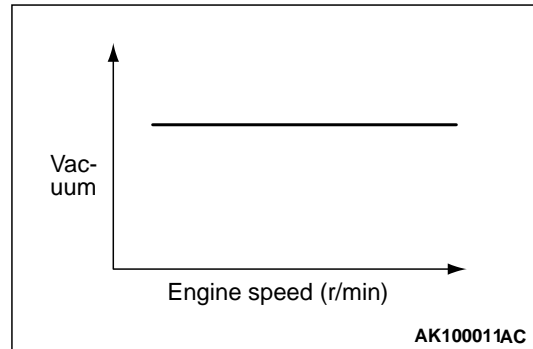

3. Start the engine.
4. Check that a fairly constant negative pressure is generated regardless of the engine speed.
5. If no negative pressure is generated, the port is probably blocked and should be cleaned.

**EGR VALVE CHECK <4G63>**

M1173002800234

1. Remove the EGR valve and inspect for sticking, carbon deposits, etc. If found, clean with a suitable solvent so that the valve seats correctly.
2. Connect a hand vacuum pump to the EGR valve.
3. Apply 67 kPa of vacuum, and check that the vacuum is maintained.

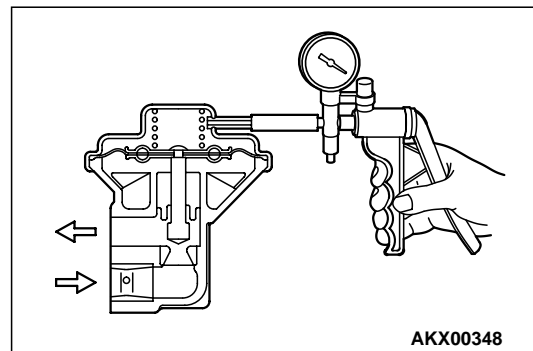

- Apply a vacuum and check the passage of air by blowing through one side of the EGR passage.

Vacuum	Passage of air
5.3 kPa or less	Air is not blown out
27 kPa or more	Air is blown out

- Replace the gasket, and tighten to the specified torque.

**Tightening torque:  $20 \pm 2$  N·m**

## EGR CONTROL SOLENOID VALVE CHECK <4G63>

M1173003100261

*NOTE: When disconnecting the vacuum hose, always make a mark so that it can be reconnected at original position.*

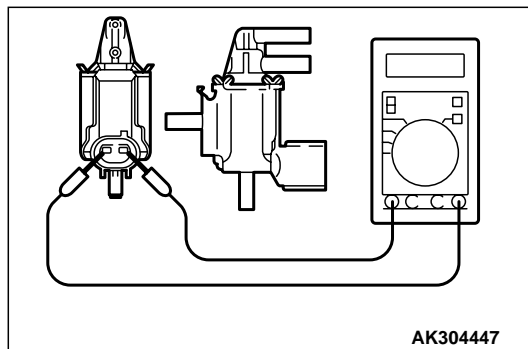
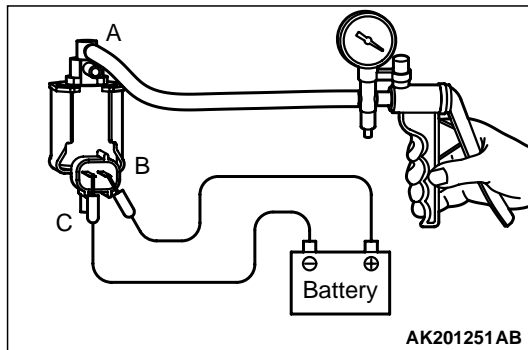

- Disconnect the vacuum hose from the solenoid valve.
- Disconnect the harness connector.
- Connect a hand vacuum pump to nipple (A) of the solenoid valve (refer to the illustration at left).
- Check air tightness by applying a vacuum with voltage applied directly from the battery to the EGR control solenoid valve and without applying voltage.

Battery voltage	B nipple condition	Normal condition
Not applied	Open	Vacuum maintained
Applied	Open	Vacuum leaks
	Closed	Vacuum maintained

- Measure the resistance between the terminals of the solenoid valve.

**Standard value:  $29 - 35 \Omega$  (at  $20^\circ\text{C}$ )**

## EGR VALVE (STEPPER MOTOR) CHECK <4G69>

M1173050200134

### Checking the Operation Sound

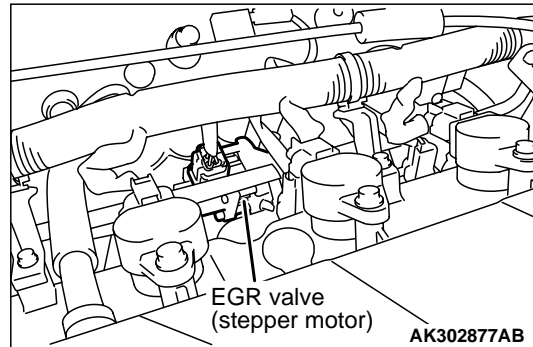

- Check that the operation sound of the stepper motor can be heard from the EGR valve when the ignition switch is turned ON (without starting the engine).
- If the operation sound cannot be heard, inspect the drive circuit of the stepper motor.

*NOTE: If the circuit is normal, either the stepper motor or the engine-ECU <M/T> or engine-A/T-ECU <A/T> may have failed.*

### Checking the Coil Resistance

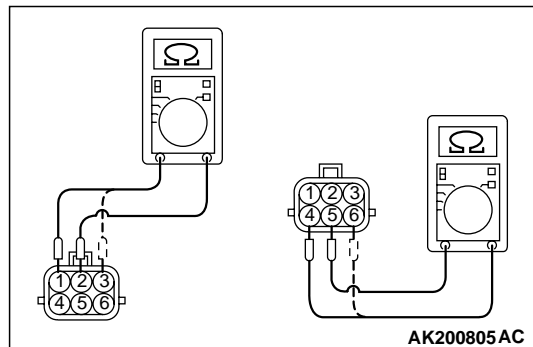

- Remove the EGR valve.

- Measure the resistance between terminal No. 2 and either terminal No. 1 or terminal No. 3 of the connector at the EGR valve.

**Standard value: 20 – 24  $\Omega$  (at 20°C)**

- Measure the resistance between terminal No. 5 and either terminal No. 6 or terminal No. 4 of the connector at the EGR valve.

**Standard value: 20 – 24  $\Omega$  (at 20°C)**

- Using a new gasket, install the EGR valve by tightening its mounting bolts to the specified torque.

**Tightening Torque: 24  $\pm$  4 N·m**

### Operation Check

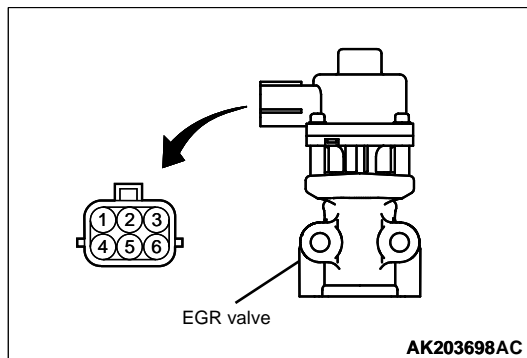

- Remove the EGR valve.
- Attach a test wiring harness (special tool MB991658) to the connector at the EGR valve.

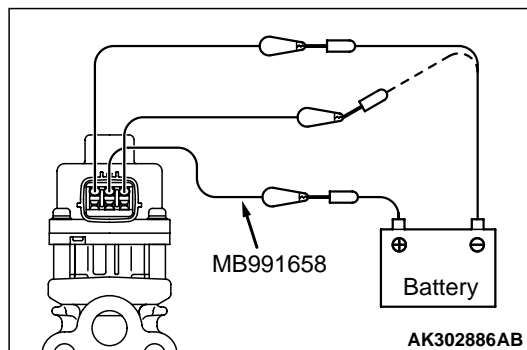

#### **CAUTION**

**Connecting battery voltage to the EGR valve for a long term could damage the coil.**

- Connect the positive (+) terminal of the battery to terminal No. 2.

- Connect terminals No. 1 and No. 3 to the negative (-) terminal of the battery, in order to test whether the stepper motor vibrates (with a slight shudder), indicating that the stepper motor is operating.

#### **CAUTION**

**Connecting battery voltage to the EGR valve for a long term could damage the coil.**

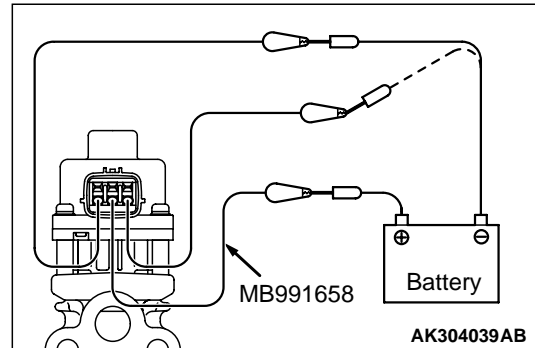

- Connect the positive (+) terminal of the battery to terminal No. 5.
- Connect terminals No. 4 and No. 6 to the negative (-) terminal of the battery, in order to test whether the stepper motor vibrates (with a slight shudder), indicating that the stepper motor is operating.
- If a vibration can be felt during the test, the stepper motor is normal.
- Using a new gasket, install the EGR valve by tightening its mounting bolts to the specified torque.

**Tightening torque: 24  $\pm$  3 N·m**

### Cleaning the EGR Valve

#### **CAUTION**

**Do not use a solvent or detergent, which could enter the motor and cause it to malfunction.**

- Remove the EGR valve and check that the EGR valve is not stuck or clogged with carbon deposits. Use a wire brush to clean the valve if necessary.
- Using a new gasket, install the EGR valve by tightening its mounting bolts to the specified torque.

**Tightening torque: 24  $\pm$  3 N·m**

**EXHAUST GAS RECIRCULATION (EGR) VALVE REMOVAL AND INSTALLATION  
<4G63>**

M1173010500249

**Pre-removal and Post-installation Operation**

Air cleaner cover and air intake hose removal and installation  
(Refer to GROUP 15 - Air cleaner P.15-3).

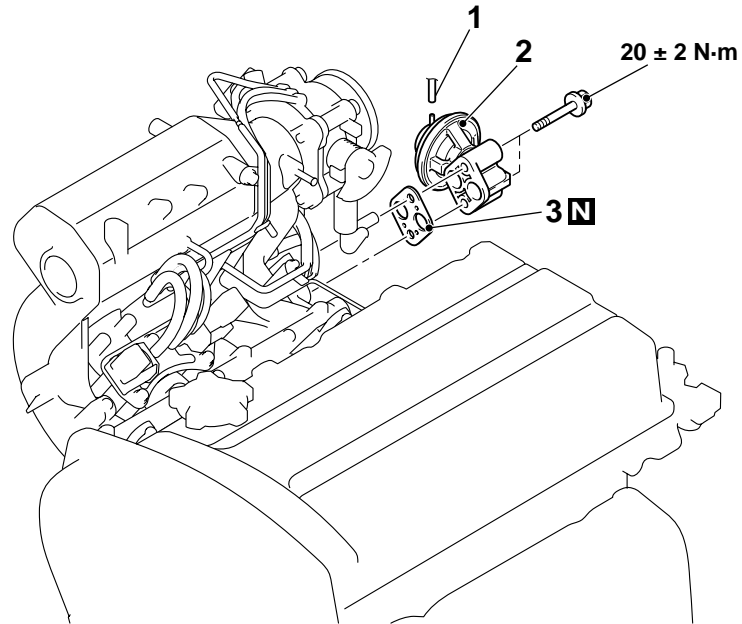

AC301219AB

**Removal steps**

1. Vacuum hose connection

**Removal steps (Continued)**

2. EGR valve
3. EGR valve gasket

**EXHAUST GAS RECIRCULATION (EGR) VALVE REMOVAL AND INSTALLATION  
<4G69>**

M1173010500250

**Pre-removal and Post-installation Operation**

Resonator removal and installation (Refer to GROUP 15 - Air cleaner P.15-4).

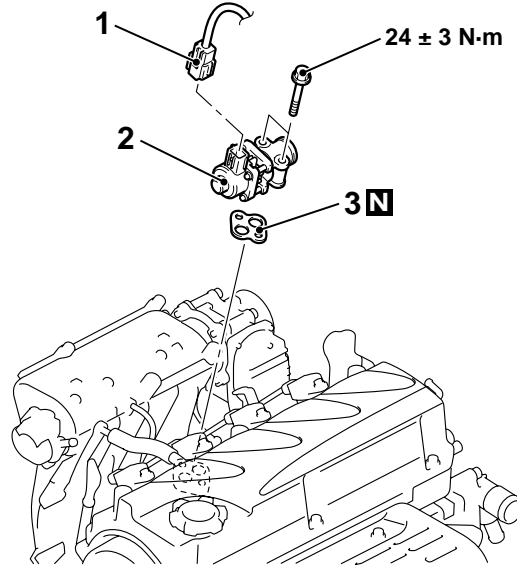

AC302329AE

**Removal steps**

- 1. EGR valve connector
- 2. EGR valve
- >>A<< 3. EGR valve gasket

**INSTALLATION SERVICE POINT**

**>>A<< EGR PIPE B GASKET INSTALLATION**

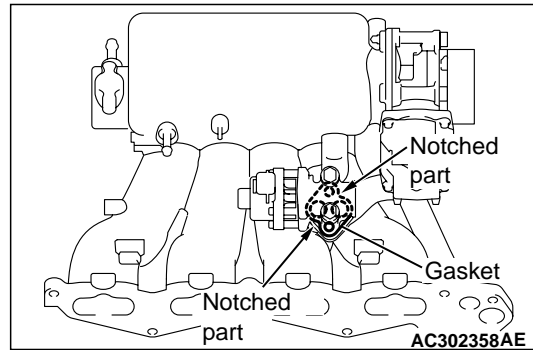

Install the EGR valve gasket as shown in the illustration.

CATALYTIC CONVERTER

REMOVAL AND INSTALLATION

M1173003900449

<4G63-2WD>

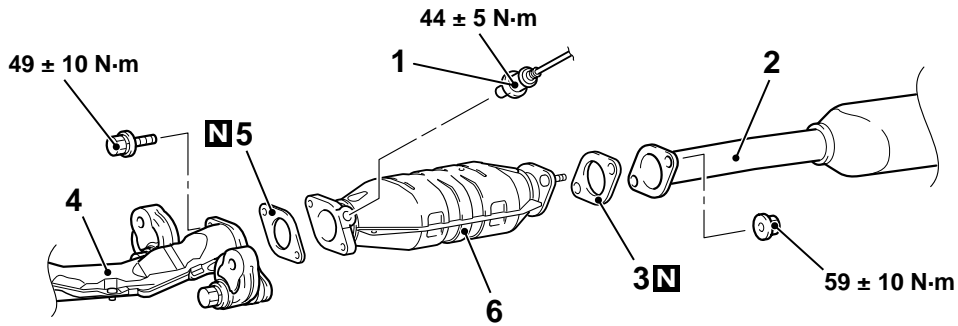

AC212564AC

<4G63-4WD>

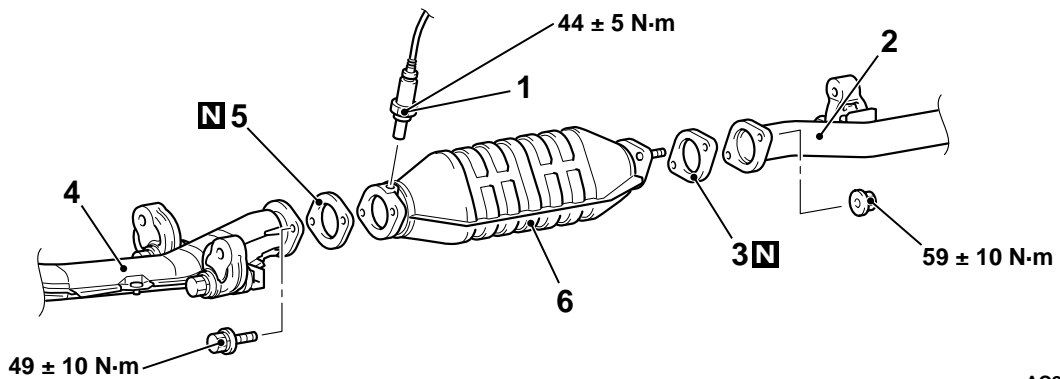

AC212565AD

<4G69>

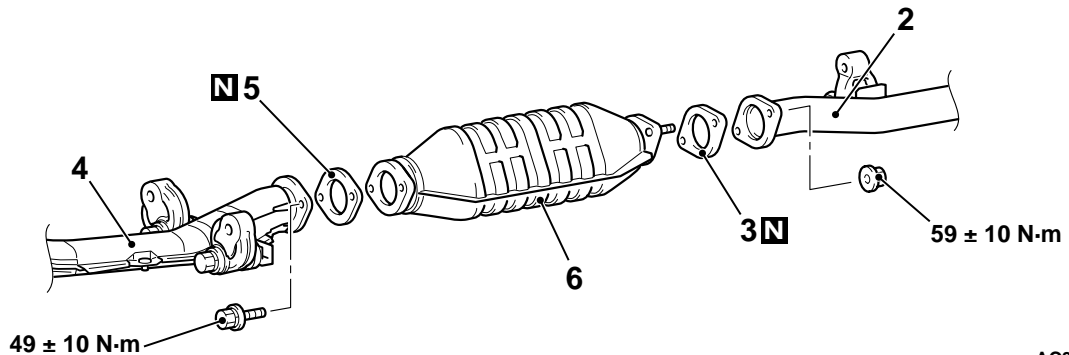

AC309495AB

<<A>> >>A<<

Removal steps

1. Oxygen sensor <4G63>
2. Center exhaust pipe connection
3. Exhaust pipe gasket

Removal steps (Continued)

4. Front exhaust pipe connection
5. Exhaust pipe gasket
6. Catalytic converter

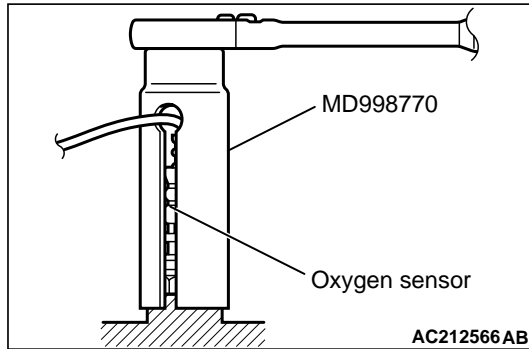
**REMOVAL SERVICE POINT****<<A>> OXYGEN SENSOR REMOVAL**

Use special tool oxygen sensor wrench (MD998770) to remove the oxygen sensor.

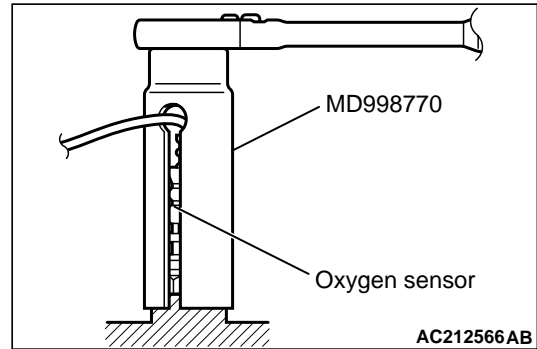
**INSTALLATION SERVICE POINT****>>A<< OXYGEN SENSOR INSTALLATION**

Use special tool oxygen sensor wrench (MD998770) to install the oxygen sensor.